

## Processing Simulation of Virtual Manufacture in Laser Surface Treatment

Taohong Zhang and Gang Yu

*Lab of Laser Intelligent Manufacturing, Institute of Mechanics, Chinese Academy of Sciences, Beijing, 100080, China*

e-mail: taohzhang1@hotmail.com, gyu@imech.ac.cn

**Abstract:** Processing simulation is at the bottom of the coral technology of VM and is also difficult due to the complexity of mechanism and diversity of parameters. Previously much research has been mainly carried out on the geometrical simulation or physical simulation respectively. The aim of this paper is to study the processing simulation in laser surface treatment based on the mechanism, put forward the architecture of the whole processing simulation and give the models of the processing. As a result the data structure layers in the whole simulation is presented.

**Key words:** Processing simulation, Laser surface treatment, Virtual manufacture

### INTRODUCTION

With the development of computer, information and the need of the market, virtual manufacture (VM) has attracted more and more attention and accepted more and more by factories and enterprises. There are lots of key techniques from virtual machining to virtual enterprise. But processing simulation is at the bottom of the coral technology of VM and is also one of the most difficulties because of the complexity of mechanism and multi- parameters including input and output. Now processing simulation is developed around cutting, welding, punching and casting process. And most of the research focuses on the cutting process. Eight universities including University of Illinois, Purdue University and Northwestern University supported by NSF/ARPA are studying the Machine Process Modeling, the content of research is involving the cutting forces, surface form errors, surface finish, stability charts, etc. in turning, milling, and drilling [1, 2]. Dynamic modeling of the cutting forces in milling was put forward by Smith, S [3]. Chi L. Jiaa used an approach to predict and detect the tool wear [4]. Laser machining, a new green machining, with the attribute of no touch, pollution free, low noise, high integrated and high efficient, is being used popularly. The process type can be cutting, welding, drilling, surface modification and rapid prototyping. And the system of laser processing is often flexible to execute many kinds of process by just changing the software modules which can be integrated easily and a few auxiliary equipments if they are needed [5]. So, as an important constitution of machining, laser machining should urgently be an important element in VM.

Laser process simulation should include the robot movement, the function of laser to the material and other service equipment movement such as transport vehicle in the virtual environment. And the simulation should not be done separately but be a full simulation. So the simulation should be a union of geometrical simulation and physical simulation. Duo to the difference of mechanism about different laser and different material, this paper analyzes the laser surface hardness on the sheet mould. When the vehicle transports the sheet mould to the area of processing, the robot moves to the first point and adjusts the posture to begin its work. With the proceeding of robot, the change of the material caused by laser should be presented by the simulation. As an example, the change of temperature at the machining point is presented. The details are discussed in the follow.

## PROCESSING SIMULATION ARCHITECTURE

Processing simulation in VM is the digital map to the real processing. It can be done based on the modeling and simulation technology. So the models and the processing should have the same performances, actions and functions as the real. Laser surface hardness system is consisted of a robot, laser machine, transporting vehicle and work piece-sheet die. Fig. 1 is the architecture of the laser surface hardness process.

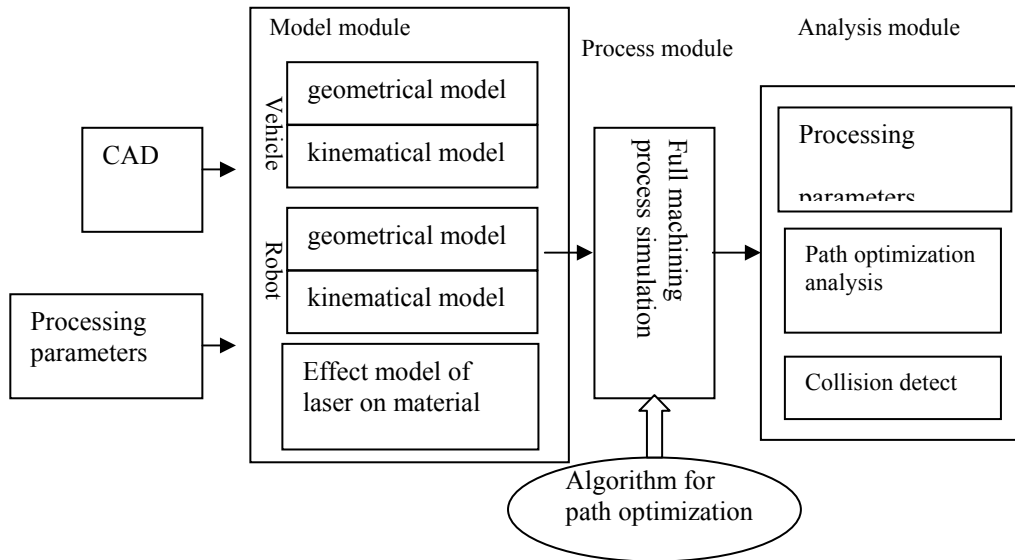

Fig. 1 Architecture of the laser surface hardness processing simulation in VM

### 1. Models in the processing

#### 1) Transporting vehicle model

(1) **geometrical model** The function of the transporting vehicle is porting the sheet die which is put on the surface of the vehicle to the working area of the robot. And it also is a worktable. So the geometrical model is a simple solid.

(2) **Kinematical model** The vehicle transports through a direct line. The kinematical form is:

$$P_2 - P_1 = v t$$

$P_2$  and  $P_1$  is the start point and the end point.  $v$  is the average speed.  $t$  is the transporting time .

#### 2) Robot model

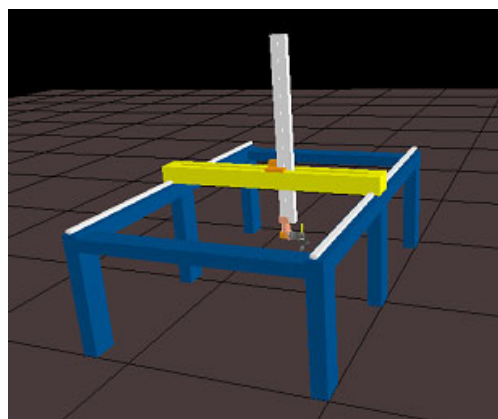

Fig.2 the Geometrical Model of 5-axis Frame Robot

**(1) geometrical model** Our robot is a 5-axis frame robot designed for the laser flexible machining system. Its model can be obtained from CAD. Fig.2 is the model of the robot.

**(2) kinematical model and inverse kinematical model** The robot has 5 DOF. These are three transferring degrees by x, y, z and two rotate degrees around axis A and C. The matrix should be:

$$T_5 = \begin{bmatrix} 1 & 0 & 0 & x \\ 0 & 1 & 0 & y \\ 0 & 0 & 1 & z \\ 0 & 0 & 0 & 1 \end{bmatrix} \bullet \begin{bmatrix} C_4 & -S_4 & 0 & 0 \\ S_4 & C_4 & 0 & 0 \\ 0 & 0 & 1 & 0 \\ 0 & 0 & 0 & 1 \end{bmatrix} \bullet \begin{bmatrix} 1 & 0 & 0 & 0 \\ 0 & 1 & 0 & -l_1 \\ 0 & 0 & 1 & 0 \\ 0 & 0 & 0 & 1 \end{bmatrix} \quad (1)$$

$$\bullet \begin{bmatrix} C_5 & 0 & S_5 & 0 \\ 0 & 1 & 0 & 0 \\ -S_5 & 0 & C_5 & 0 \\ 0 & 0 & 0 & 1 \end{bmatrix} \bullet \begin{bmatrix} -1 & 0 & 0 & 0 \\ 0 & 1 & 0 & 0 \\ 0 & 0 & -1 & 0 \\ 0 & 0 & 0 & 1 \end{bmatrix}$$

$T_5$  is the kinematical matrix. The transforming value is x, y, z.  $C_4$  is a cosine value, standing for the rotation around axis A.  $S_4$  is the sine value.  $C_5$  (cosine value) is the rotation around axis C, and  $S_5$  is the sine value.  $l_1$  is the length of machining arm.

The inverse kinematical relation has two solutions. We choose one according to the real machining. It is showed in Equ.2.

$$\begin{aligned} P_x &= x + S_4 l_1 + a_x \cdot T_l \\ P_y &= y - C_4 l_1 + a_y \cdot T_l \\ P_z &= z + a_z \cdot T_l \\ A &= \arctan(a_y / a_x) \\ C &= \arccos(-a_z) \end{aligned} \quad (2)$$

$P_x, P_y, P_z$  is the magnitude of transforming along x, y and z direction respectively. A and C are the angles rotating by axis A and axis C.

**3) Effect model of the laser on the material** When the sheet die is exposed to the laser, heat conduction plays an important role. The energy absorbed by the material changes into heat energy. The heating process can be described by Fourier's law of heat conduction and the laser pulse can be considered as a surface heat source. During laser processing, some heat energy is lost due to convection and radiation, but research indicated that these kind energy losses can be neglected [6].

The corresponding boundary condition is specified temperature  $T=T(\Gamma_1, t)$  on boundary  $\Gamma_1$  and specified heat flow  $q=q(\Gamma_2, t)$  on boundary  $\Gamma_2$ , where  $\Gamma_1+\Gamma_2=\Gamma_{\text{total}}$  (entire boundary). The initial condition is  $T=T_0(x, y, z)$ . And the quantity of heat released or absorbed  $Q$  is the function of temperature  $T$  when phase transformation taking place and in present study the linear assumption is adopted, then the equation is:

$$\rho \bar{c} \frac{\partial T}{\partial t} = \nabla \cdot (k \nabla T) \quad (3)$$

where  $\rho$  is the material density,  $\bar{c}=c+c_q$  is called average specific heat,  $c$  the specific heat, and  $c_q$  is the equal specific heat,  $k$  the thermal conductivity. The transient temperature field can be obtained by Solving Eq.(3).

The laser machine we used is a continuous Nd:YAG laser machine with the wavelength of  $1.06\mu\text{m}$ . The action spot is a square (Fig.3). In present study, the spatial intensity distribution of laser pulse is controlled to be uniform rectangle and the temporal intensity distribution is also set to uniform during entire pulse duration. The surface absorption coefficient is assumed to be a constant of 0.25 according to experiment. The related parameters of laser source are shown in Table 1. At the laser is projecting on the surface, the time is set to  $t=0\text{ms}$ , with the time going, the value of temperature is higher, and with the off of laser, it will be lower (Fig. 4). As the robot moves to the next machining point, the time proposed to be 160ms, the laser is on again. The temperature field is shown in Fig. 5.

*Table 1 Laser Parameters*

|                          |      |
|--------------------------|------|
| Pulse power (W)          | 2000 |
| Pulse duration (ms)      | 80   |
| Duty ratio               | 1/2  |
| Spot size (mm×mm)        | 3×3  |
| Separation of spots (mm) | 0.3  |

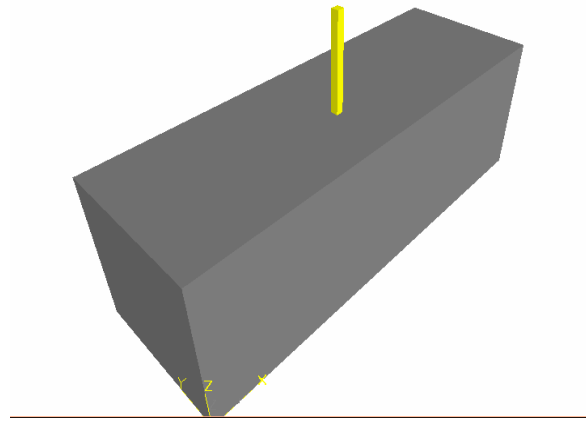

*Fig. 3 Square Laser and Material*

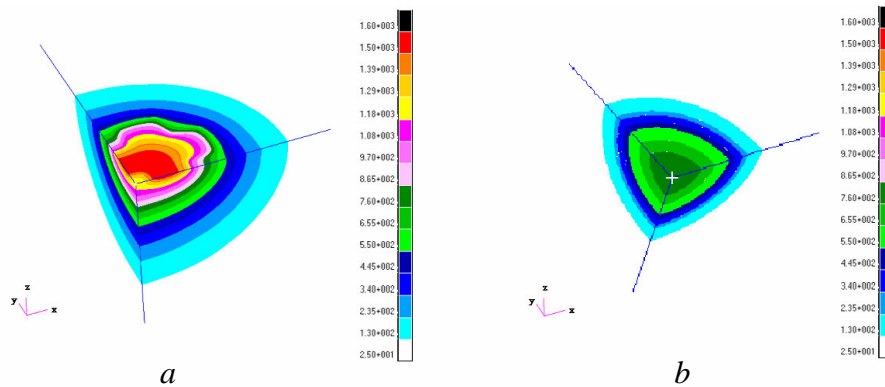

*Fig.4 Temperature field (a)  $t=86\text{ms}$  (b)  $t=110\text{ms}$*

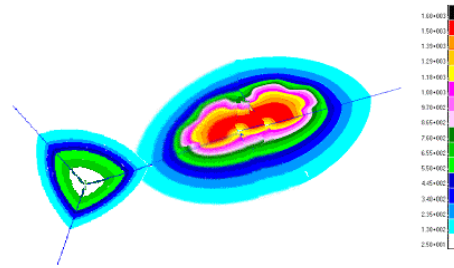

Fig. 5 Temperature at the two near points  $t=320ms$

### DATA STRUCTURE IN THE PROCESSING SIMULATION

There is a large quantity of data in the full processing simulation. The data structure is showed in Fig.6.

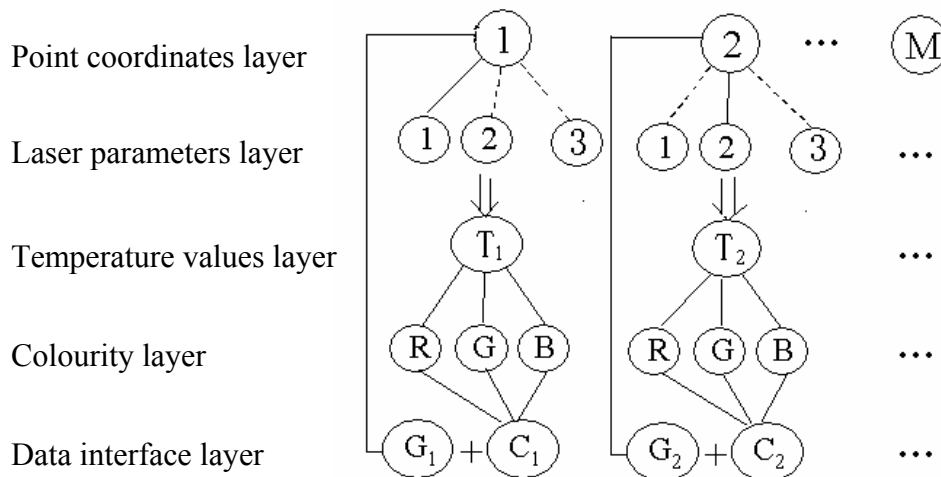

Fig. 6 Data structure in the full processing simulation

The first layer is the coordinate values of processing points, which are the center of the squares(3mm×3mm) of processing area. Different laser processing parameters will cause different temperature field, so the second layer is the laser parameters layer, and the result of temperature values is put to the third layer. In virtual environment the result of simulation should be displayed directly, and colourity is a good choice. So different values of R,G and B are different colors to stand for the different temperature values. Based on these, the geometry data of points and the values of colourity are on the interface layer.

### CONCLUSION

The continuous quest for high quality products(Q), lower manufacturing costs(C), faster time-to-market(T), better service(S) and smaller pollution to environment(E) will make the future of VM more exciting. VM is the major construction of concurrent engineering(CE) and agile manufacturing(AM). The processing simulation is the base key technique in the VM. And it's also being one of the bottlenecks of VM.

This paper gives a full simulation of laser surface hardness. It includes the building of models and the integration into the virtual environment. The result is displayed by the values of temperature in the action area. The virtual environment is built based on IGRIP software. The result of simulation can be used not only to optimize the processing plan and path plan, but to detect the collision happened in the processing.

**Acknowledgements** This research work was sponsored by Chinese Academy of Sciences through Grant KGCX1-11.

## REFERENCES

- [1] Girishbabu Parakkal, Rixin Zhu, Shiv G. Kapoor and Richard E. DeVor, *Modeling of turning process cutting forces for grooved tools*, International Journal of Machine Tools and Manufacture, 42(2), January (2002), 179-191.
- [2] Sushanta K. Sahu, O. Burak Ozdoganlar, Richard E. DeVor and Shiv G. Kapoor *Effect of groove-type chip breakers on twist drill performance*, International Journal of Machine Tools and Manufacture, 43(6), May (2003), 617-627.
- [3] Smith, S., and Tlusty, J., *Update on High-Speed Milling Dynamics*, ASME Journal of Engineering For Industry, 112(2), (1990), 142.
- [4] Chi L. Jiaa and David A. Dornfeld , *A self-organizing approach to the prediction and detection of tool wear*, ISA Transactions, 37(4), September (1998), 239-255.
- [5] Yu G, Yu H J. *Integrated Laser Intelligent Manufacturing*. Beijing: Metallurgic Industry Press, (2002), (in Chinese).
- [6] Li J C. *Diffraction of Laser and Calculation on Thermal Acting*. Beijing: Science Press, (2002), (in Chinese).