

## **A discussion about a class of stress intensity factors and its verification**

JIANG CHI-PING<sup>1</sup>, ZOU ZHEN-ZHU<sup>2</sup>, WANG DUO<sup>2</sup> and LIU YOU-WEN<sup>3</sup>

<sup>1</sup>*Institute of Mechanics, Chinese Academy of Sciences, Beijing, 100080, People's Republic of China;*

<sup>2</sup>*Harbin Institute of Technology, People's Republic of China;* <sup>3</sup>*Central-South University of Technology, People's Republic of China*

Received 1 December 1988; accepted in revised form 11 January 1990

**Abstract.** In this paper, new formulae of a class of stress intensity factors for an infinite plane with two collinear semi-infinite cracks are presented. The formulae differ from those gathered in several handbooks used all over the world. Some experiments and finite element calculations have been developed to verify the new formulae and the results have shown its reliability. Finally, the new formulae and the old are listed to show the differences between them.

### **1. Introduction**

In application of the theory of linear fracture mechanics to solve a practical problem, the most important thing is to determine the stress intensity factors at the tips of a crack, so several handbooks which contain the research results of many scholars were published in the 1970s and 1980s for the convenience of engineers and scientific researchers. In this paper the formulae, which are listed in several handbooks, of a class of stress intensity factors for an infinite plane with two collinear semi-infinite cracks are reexamined. It has been found that some of the formulae are not correct because of the failure to consider the resultant vector and moment of internal forces acting along the finite bonded line of two half-planes. In this paper, the mistakes have been corrected by solving the problems by means of the complex function method.

The main idea in this paper is that the two half-planes, which are cut out from a whole plane by two collinear semi-infinite cracks, are separated at infinity, so a relative rotation at infinity between them may exist. From the mathematical point of view, the difference  $C_i$  between the two imaginary constants in complex stress functions  $\phi_1(z)$  and  $\phi_2(z)$  of the two half-planes is related to the relative rotation. As we will see, the  $C_i$  affects the field of stresses and can be determined by an additional condition uniquely, which is, to our knowledge, proposed for the first time.

The reliability of the new formulae has been verified by experiments and finite element calculations.

### **2. Statement of the problem**

It is assumed that the two infinite half-planes are bonded together along a small central part and the two semi-infinite cracks are free from tractions (Fig. 1). Two pairs of concentrated

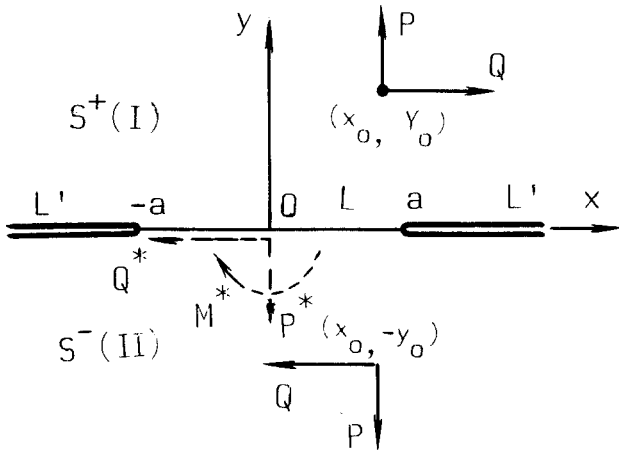

Fig. 1

forces  $(P, Q)$  are acting at the points  $(x_0, y_0)$  and  $(x_0, -y_0)$  symmetrically with respect to the  $X$ -axis.

The upper and lower half-planes  $S^+, S^-$  are occupied by homogeneous and isotropic materials I and II respectively. The bonded segment of the two half-planes along the  $X$ -axis is denoted by  $L$  and the other two segments by  $L'$ . If  $\sigma_x, \sigma_y, \tau_{xy}$  and  $u, v$  represent the stress and displacement components in a right hand coordinate system, the boundary

and continuous conditions of the two half-planes along the  $X$ -axis are as follows:

(I) The stresses are equal to each other along the  $X$ -axis and the surfaces of the cracks are free from tractions.

$$[\sigma_y - i\tau_{xy}]^+ = [\sigma_y - i\tau_{xy}]^- \quad \text{on } L + L', \tag{2.1}$$

$$[\sigma_y - i\tau_{xy}]^+ = [\sigma_y - i\tau_{xy}]^- = 0 \quad \text{on } L'. \tag{2.2}$$

For the convenience of analysis, the above two expressions are written in a complex form, where the superscripts denote the limit values of the stresses as the arguments approach the  $X$ -axis from  $S^+$  and  $S^-$ , respectively.

(II) The displacements are equal to each other along the bonded segment of the two half-planes.

$$[u + iv]^+ = [u + iv]^- \quad \text{on } L. \tag{2.3}$$

Also, the resultant vector and the moment of the internal forces, with which the lower half-plane acts as the upper one along the bonded segment, have to be prescribed. So the following two additional conditions are obtained:

$$\int_{-a}^a [\sigma_y - i\tau_{xy}]^+ dx = P^* - iQ^*, \tag{2.4}$$

$$\int_{-a}^a x\sigma_y^+ dx = M^*, \tag{2.5}$$

where  $a$  is the half length of the bonded segment of the two half-planes. The method for determining the resultant vectors  $P^*, Q^*$  and moment  $M^*$  will be described in Section 4.

### 3. Riemann-Hilbert problem

Referring to [6] and [7], the solution of a plane problem in elasticity can be expressed in terms of two analytical functions as follows:

$$\sigma_x + \sigma_y = 2[\phi(z) + \overline{\phi(z)}], \quad (3.1)$$

$$\sigma_y - i\tau_{xy} = \phi(z) + \overline{\phi(z)} + z\overline{\phi'(z)} + \overline{\Psi(z)}, \quad (3.2)$$

$$2\mu(u' + iv') = \kappa\phi(z) - \overline{\phi(z)} - z\overline{\phi'(z)} - \overline{\Psi(z)}, \quad (3.3)$$

where

$$u' = \frac{\partial u}{\partial x}, \quad v' = \frac{\partial v}{\partial x}, \quad (3.4)$$

and the upper bar denotes the conjugate of a relevant complex function,  $\mu$  is the shear modulus,  $\nu$  is the Poisson ratio,  $\kappa = 3-4\nu$  for plane strain problem and  $\kappa = (3 - \nu)/(1 + \nu)$  for a generalized plane stress problem. If  $\phi(z)$  and  $\Psi(z)$  are defined in the upper half plane  $S^+$  we can extend  $\phi(z)$  into the lower half-plane  $S^-$  through the traction-free segments of the real axis:

$$\phi(z) = -\overline{\phi(z)} - z\overline{\phi'(z)} - \overline{\Psi(z)} \quad z \in S^-, \quad (3.5)$$

where  $\overline{\phi(z)} = \phi(\bar{z})$ . Thus  $\Psi(z)$ , which is defined in  $S^+$ , can be expressed by the extended  $\phi(z)$

$$\Psi(z) = -\phi(z) - \overline{\phi(z)} - z\overline{\phi'(z)} \quad z \in S^+. \quad (3.6)$$

So (3.2) and (3.3) can be written in the following form:

$$\sigma_y - i\tau_{xy} = \phi(z) + \phi(\bar{z}) + (z - \bar{z})\overline{\phi'(z)} \quad z \in S^+, \quad (3.7)$$

$$2\mu(u' + iv') = \kappa\phi(z) + \phi(\bar{z}) - (z - \bar{z})\overline{\phi'(z)} \quad z \in S^-. \quad (3.8)$$

It is apparent that we can exchange the positions of  $S^+$  and  $S^-$  in the above formulae.

Let subscripts 1 and 2 refer to the materials I and II respectively. As the concentrated forces  $P$  and  $Q$  are applied at the point  $z_0 = x_0 + iy_0$  in the upper half-plane, the principal part of singularity of the stress function  $\phi_1(z)$ , which is defined in  $S^+$ , is  $M_1/(z - z_0)$ ; and that of  $\Psi_1(z)$ , which is also defined in  $S^+$ , is

$$\frac{N_1}{z - z_0} + \frac{\bar{z}_0 M_1}{(z - z_0)^2},$$

where

$$M_1 = -\frac{Q + iP}{2\pi(1 + \kappa)}, \quad N_1 = \frac{\kappa(Q - iP)}{2\pi(1 + \kappa)}.$$

Then, according to (3.5), the extended  $\phi_1(z)$  can be expressed as follows:

$$\phi_1(z) = \frac{M_1}{z - z_0} - \frac{\bar{N}_1}{z - \bar{z}_0} + \frac{\bar{M}_1(\bar{z}_0 - z_0)}{(z - \bar{z}_0)^2} + \phi_{10}(z), \quad (3.9)$$

where  $\phi_{10}(z)$  is holomorphic in the whole plane cut along  $L$  (bonded segment). It can be assumed that the rotation of the upper plane at infinity is zero, then:

$$\phi_{10}(\infty) = \phi_1(\infty) = 0. \quad (3.10)$$

Similarly,  $\phi_2(z)$ , which is defined in  $S^-$ , can be extended and expressed as

$$\phi_2(z) = -\frac{M_1}{z - \bar{z}_0} + \frac{\bar{N}_1}{z - z_0} - \frac{\bar{M}_1(z_0 - \bar{z}_0)}{(z - z_0)^2} + \phi_{20}(z), \quad (3.11)$$

where  $\phi_{20}(z)$  is also holomorphic in the whole complex plane cut along  $L$ . As the two half-planes are not connected at infinity, the rotation of the lower half-plane can no longer be set to zero. So

$$\phi_{20}(\infty) = \phi_2(\infty) = Ci, \quad (3.12)$$

where  $C$  is a real constant. It will be seen that for one half-plane problem an arbitrary imaginary constant included in  $\phi(z)$  does not affect the field of stresses; for the problem of two half-planes bonded together along a small segment, however, the difference between the two constants will surely be related to the field.

Let  $t$  be a point on the real axis, from (2.1) and (3.7) we obtain

$$\phi_1^+(t) - \phi_1^-(t) = \phi_2^-(t) - \phi_2^+(t) \quad \text{on } L + L'. \quad (3.13)$$

Substituting (3.9) and (3.11) into (3.13), we arrive at the following expression:

$$[\phi_{10}(t) + \phi_{20}(t)]^+ - [\phi_{10}(t) + \phi_{20}(t)]^- = 0 \quad \text{on } L + L'. \quad (3.14)$$

According to the Liouville's theorem:

$$\phi_{10}(z) + \phi_{20}(z) = Ci, \quad (3.15)$$

taking the derivatives of both sides of (2.3) with respect to  $x$  and making use of (3.8), we obtain

$$\kappa\phi_1^+(t) + \phi_1^-(t) = \kappa\phi_2^-(t) + \phi_2^+(t) \quad \text{on } L. \quad (3.16)$$

Considering (3.9), (3.11), (3.15), after some rearrangement, we obtain

$$\phi_{10}^+(t) + \phi_{10}^-(t) = f(t) \quad \text{on } L, \tag{3.17}$$

where

$$\begin{aligned} f(t) = & \frac{Q + iP}{2\pi} \left( \frac{1}{t - z_0} + \frac{1}{t - \bar{z}_0} \right) + \frac{Q - iP}{2\pi(1 + \kappa)} (z - \bar{z}_0) \\ & \times \left[ \frac{1}{(t - z_0)^2} - \frac{1}{(t - \bar{z}_0)^2} \right] + Ci. \end{aligned} \tag{3.18}$$

After a series of manipulations, the solution of (3.17) can be obtained:

$$\begin{aligned} \phi_{10}(z) = & \frac{Q + iP}{4\pi} \left( \frac{1}{z - z_0} + \frac{1}{z - \bar{z}_0} \right) + \frac{Q - iP}{4\pi(1 + \kappa)} (z_0 - \bar{z}_0) \left[ \frac{1}{(z - z_0)^2} - \frac{1}{(z - \bar{z}_0)^2} \right] \\ & + \frac{Ci}{2} - \frac{Q + iP}{4\pi\sqrt{z^2 - a^2}} \left[ \frac{\sqrt{z_0^2 - a^2}}{z - z_0} + \frac{\sqrt{\bar{z}_0^2 - a^2}}{z - \bar{z}_0} \right] - \frac{(Q - iP)(z_0 - \bar{z}_0)}{4\pi(1 + \kappa)\sqrt{z^2 - a^2}} \\ & \times \left[ \frac{\sqrt{z_0^2 - a^2}}{(z - z_0)^2} - \frac{\sqrt{\bar{z}_0^2 - a^2}}{(z - \bar{z}_0)^2} + \frac{1}{z - z_0} \cdot \frac{z_0}{\sqrt{z_0^2 - a^2}} - \frac{1}{z - \bar{z}_0} \cdot \frac{\bar{z}_0}{\sqrt{\bar{z}_0^2 - a^2}} \right] \\ & - \frac{Ciz}{2\sqrt{z^2 - a^2}} + \frac{C_1^*}{\sqrt{z^2 - a^2}}, \end{aligned} \tag{3.19}$$

where

$$C_1^* = C_1 - \frac{Q + iP}{2\pi}. \tag{3.20}$$

#### 4. Determination of the constants

The real and complex constants  $C$  and  $C_1^*$  in the expression (3.19) can be determined from the conditions (2.4) and (2.5) uniquely. So from the mathematical point of view, one could not solve the problem in hand uniquely without the consideration of those two additional conditions.

Now we analyze the coefficient of  $1/z$  in the expanded expression of function  $\phi_1(z)$  at infinity instead of the condition (2.4) itself.

Let us consider the upper half-plane only. It is self-apparent that the resultant vector of the external forces acting within a finite area in the upper half-plane is equal to  $Q + iP - (Q^* + iP^*)$ .

According to [6], for  $|z|$  is large enough, the following asymptotic expansion is valid:

$$\phi_1(z) = \left( -\frac{Q + iP}{2\pi} + \frac{Q^* + iP^*}{2\pi} \right) \frac{1}{z} + O\left(\frac{1}{z^2}\right). \quad (4.1)$$

Substituting (3.19) into (3.9) and expanding it at infinity, then comparing the coefficient of  $1/z$  with the one in expression (4.1), we obtain

$$C_1^* = -\frac{Q + iP}{2\pi} + \frac{Q^* + iP^*}{2\pi}. \quad (4.2)$$

Now we consider the condition (2.5). Apparently it can be written as

$$\operatorname{Re} \int_{-a}^a x(\sigma_x - i\tau_x)^+ dx = M^*, \quad (4.3)$$

where  $\operatorname{Re}$  denotes the real part of a complex function. Using (3.7) and noting  $z = x$  on the real axis, (4.3) becomes

$$\operatorname{Re} \int_a^a z[\phi_1^+(z) - \phi_1^-(z)] dz = M^*, \quad (4.4)$$

where the integral on the left side of (4.4) can be reduced to a contour integration in a complex plane. In terms of the residue theorem we can determine the constant  $C$

$$\begin{aligned} C = & \frac{P}{\pi a^2} (z_0 + \bar{z}_0 - \sqrt{z_0^2 - a^2} - \sqrt{\bar{z}_0^2 - a^2}) \\ & + \frac{P(z_0 - \bar{z}_0)}{\pi(1 + \kappa)a^2} \left( \frac{z_0}{\sqrt{z_0^2 - a^2}} - \frac{\bar{z}_0}{\sqrt{\bar{z}_0^2 - a^2}} \right) - \frac{2M^*}{\pi a^2}. \end{aligned} \quad (4.5)$$

In the case, in which a concentrated force and a moment are applied at one surface of a crack simultaneously (problem 14 in the Appendix), the extended function  $\phi_1(z)$  can be written as

$$\phi_1(z) = -\frac{Q + iP}{2\pi} \cdot \frac{1}{z - b} - \frac{Mi}{2\pi} \frac{1}{(z - b)^2} + \phi_{10}(z), \quad (4.6)$$

where  $\phi_{10}(z)$  is holomorphic in the whole plane cut along  $L$ . In the same way we obtain

$$\begin{aligned} \phi_1(z) = & -\frac{Q + iP}{4\pi} \cdot \frac{1}{z - b} - \frac{iM}{4\pi} \cdot \frac{1}{(z - b)^2} - \frac{Q + iP}{4\pi} \cdot \frac{\sqrt{b^2 - a^2}}{\sqrt{z^2 - a^2}(z - b)} \\ & - \frac{iM}{4\pi} \cdot \frac{\sqrt{b^2 - a^2}}{\sqrt{z^2 - a^2}} \cdot \frac{1}{(z - b)^2} - \frac{iM}{4\pi} \cdot \frac{b}{\sqrt{b^2 - a^2}} \cdot \frac{1}{\sqrt{z^2 - a^2}(z - b)} \end{aligned}$$

$$\begin{aligned}
 & + \frac{i}{2\pi a^2} \left[ P(b - \sqrt{b^2 - a^2}) + M \left( 1 - \frac{b}{\sqrt{b^2 - a^2}} \right) - 2M^* \right] \\
 & \times \left( 1 - \frac{z}{\sqrt{z^2 - a^2}} \right) + \left( -\frac{Q + iP}{4\pi} + \frac{Q^* + iP^*}{2\pi} \right) \frac{1}{\sqrt{z^2 - a^2}}. \tag{4.7}
 \end{aligned}$$

Because the problems dealt with in this paper are all linear elastic, for other loading cases the solutions can be constructed by taking the particular forms of the above stress functions or their superpositions.

In the last part of this section two examples are given to demonstrate how to determine  $P^*$ ,  $Q^*$  and  $M^*$  in a practical engineering problem. As is well known, an actual structural component cannot be infinite in size in a mathematical sense, if a plate is large enough, however, as a mathematical abstraction, an infinite plane will be a good model for solving the problem. Let us consider a plate with two collinear cracks (Fig. 2). The applied forces near the tip of the crack or far away from it are denoted by solid arrowed lines and the resultant vector and moment with respect to the origin of the internal forces, with which the lower half plane act at the upper one, are denoted by dotted lines.

From equilibrium conditions it is easy to obtain

$$P^* = P, \quad Q^* = Q, \quad M^* = Pb, \tag{4.8}$$

for the problem in Fig. 2(a)

$$P^* = \frac{1}{2}P, \quad Q^* = 0, \quad M^* = \frac{1}{2}M + \frac{1}{2}Pb, \tag{4.9}$$

for the one in Fig. 2(b).

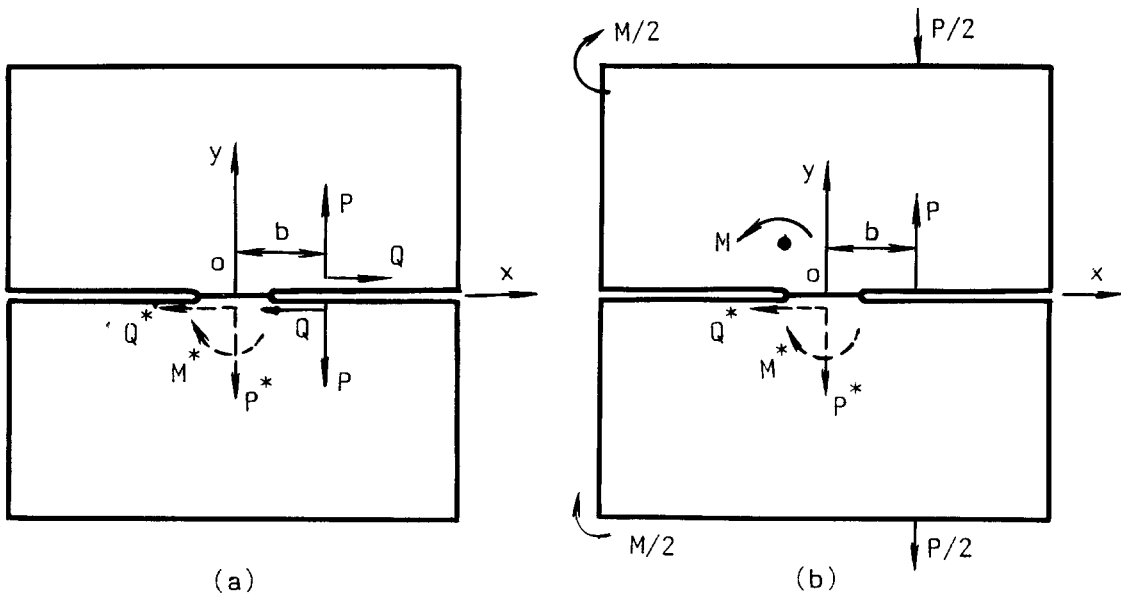

Fig. 2

It is self-evident that the influence of the load far away from the tip on the field of stress near the tip can be expressed by the terms  $P^*$ ,  $Q^*$  and  $M^*$ . Thus for the problem in Fig. 2(a) (the idealization of it is shown in the Appendix, problem (6)), from (3.9), (3.19), (4.2), (4.5) and (4.8), the complex stress function can be written as follows:

$$\phi_1(z) = -\frac{Q + iP}{2\pi} \cdot \frac{\sqrt{b^2 - a^2}}{\sqrt{z^2 - a^2}(z - b)} - \frac{Pi\sqrt{b^2 - a^2}}{\pi a^2} \left(1 - \frac{z}{\sqrt{z^2 - a^2}}\right). \quad (4.10)$$

## 5. Comparison of the stress intensity factors and some comments on the relevant references

The stress intensity factors at the tips of a crack can be defined in the following complex form:

$$(K_I - iK_{II})_{+a} = 2\sqrt{2\pi} \lim_{x \rightarrow a-0} (a - x)^{1/2} \phi_1^+(x), \quad (5.1)$$

$$(K_I - iK_{II})_{-a} = 2\sqrt{2\pi} \lim_{x \rightarrow -a+0} (a + x)^{1/2} \phi_1^+(x), \quad (5.2)$$

For the problem in Fig. 2(a) (the Appendix, problem 6), by using the complex stress function (4.10), the stress intensity factor at the tip of the crack is

$$(K_I - iK_{II})_{+a} = \frac{P - iQ}{\sqrt{\pi a}} \sqrt{\frac{b+a}{b-a}} + \frac{2P\sqrt{b^2 - a^2}}{\pi a\sqrt{a}}. \quad (5.3)$$

The formulae of the stress intensity factors, which are obtained in the same exact way as the one above, are listed in the Appendix.

The corresponding old formulae, which are gathered in several handbooks of stress intensity factors used all over the world, are also listed to show the differences between them.

The main contribution of our research work is that we point out for the first time that in order to obtain a complete solution in the mathematical sense for the problems in hand, it is absolutely necessary to take the resultant vector  $P^*$ ,  $Q^*$  and moment  $M^*$  into account, which turns out to be the consideration of the situation of loading and constraints in the vicinity of the infinity. For simplicity, in the problems listed in the Appendix, we have assumed that if the external loads acting on a finite area near to the tips of the cracks are in equilibrium, no tractions are acting at the infinity (the area far away from the tips of the cracks), as shown in Fig. 2(a); if the loads on a finite area are not in equilibrium, half of the loads, which are acting at the infinity to balance the corresponding loads in the area near to the tips of the cracks, are applied to the upper half-plane and the other half part to the lower one as shown in Fig. 2(b). For example, for problem (14) in the Appendix, the following expressions have been used:

$$P^* = \frac{1}{2}P, \quad Q^* = \frac{1}{2}Q, \quad M^* = \frac{1}{2}M + \frac{1}{2}Pb. \quad (5.4)$$

The formulae in general loading cases can be obtained by superposition with the formulae of problems (4) and (5) in the Appendix.



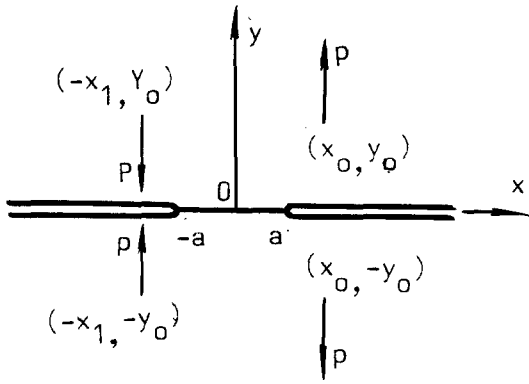

Fig. 3

To show the reliability of the new formulae, let us examine the new and old formulae in the problem in Fig. 3 (from problem (10) in the Appendix).

$$K_{I\pm a} = \frac{P}{\sqrt{\pi a}} \left[ 1 - \alpha y \frac{\partial}{\partial y_0} \right] \times \frac{1}{2} \left\{ \sqrt{\frac{z_0 \mp a}{z_0 \pm a}} + \sqrt{\frac{\bar{z}_0 \mp a}{\bar{z}_0 \pm a}} - \sqrt{\frac{z_1 \mp a}{z_1 \pm a}} - \sqrt{\frac{\bar{z}_1 \mp a}{\bar{z}_1 \pm a}} \right\}, \quad (5.5)$$

where

$$\alpha = \begin{cases} \frac{1}{2}(1 + \nu) & \text{for plane stress problem,} \\ \frac{1}{2} \cdot \frac{1}{1 - \nu} & \text{for plane strain problem,} \end{cases}$$

cited from [1] and [2].

$$K_{I\pm a} = \frac{P}{\sqrt{\pi a}} \left[ 1 - \alpha_0 y_0 \frac{\partial}{\partial y_0} \right] \frac{1}{2} \left\{ \sqrt{\frac{z_0 \pm a}{z_0 \mp a}} + \sqrt{\frac{\bar{z}_0 \pm a}{\bar{z}_0 \mp a}} - \sqrt{\frac{z_1 \pm a}{z_1 \mp a}} - \sqrt{\frac{\bar{z}_1 \pm a}{\bar{z}_1 \mp a}} \right\} \pm \frac{P}{a\sqrt{\pi a}} (A_0 - A_1), \quad (5.6)$$

where

$$A_j = \sqrt{z_j^2 - a^2} + \sqrt{\bar{z}_j^2 - a^2} - \frac{\alpha}{2} (z_j - \bar{z}_j) \left( \frac{z_j}{\sqrt{z_j^2 - a^2}} - \frac{\bar{z}_j}{\sqrt{\bar{z}_j^2 - a^2}} \right), \quad j = 0, 1 \text{ from this paper.} \quad (5.7)$$

Apparently, if  $y_0 \rightarrow \infty$  and  $P(x_0 + x_1) = M$ , the above problem is reduced to problem (3) or problem (4) (problems (3) and (4) are the same problem essentially).

According to the old formula,  $\lim_{y_0 \rightarrow \infty} K_I = 0$ . It is in contradiction with the formula in problem (3) in the Appendix, in which  $K_I = 2M/(a\sqrt{\pi a})$ .

According to the new formula,  $\lim_{y_0 \rightarrow \infty} K_I = 2M/(a\sqrt{\pi a})$ , which coincides with the formulae in problem (3) and problem (4).

Now we would like to make some comments on two representative references. In the field of fracture mechanics, [4] is a very important treatise, which has solved the problem of the stress distribution in plates with collinear cuts under arbitrary loads, and has been cited by many scholars. The whole deduction is correct, except for a small oversight. That is, the

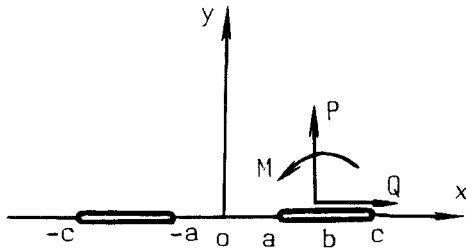

Fig. 4

author has regarded the plane problem with two collinear semi-infinite cracks as a limit case of the problem in Fig. 4 by letting  $c \rightarrow \infty$ . It should be pointed out that this limiting process is not proper. A relative rotation of the two half-planes may exist and  $P^*$ ,  $Q^*$  and  $M^*$  on the finite bonded segment have to be considered for the problem with two collinear semi-infinite cracks,

whereas the relative rotation of the two half-planes in the problem shown in Fig. 4 has to be zero and there is no need to consider  $P^*$ ,  $Q^*$  and  $M^*$ , which are finite in magnitude.

In [5] a problem of a nonhomogeneous elastic plane with two semi-infinite cracks was dealt with. The author developed an elegant method, which has been followed in this paper. The author pointed out that  $P^*$  and  $Q^*$  on the finite bonded segments have to be prescribed, but failed to consider  $M^*$  and thus failed to consider the imaginary constant  $Ci$ . If (14) in [5] was changed to

$$\phi_2(z) = Ci + \frac{P + iQ}{2\pi z} + O\left(\frac{1}{z^2}\right), \tag{5.8}$$

for large values of  $|z|$  and  $Ci$  was determined in terms of  $M^*$  (see (4.4) in this paper), then the solutions (in the case of  $\kappa_1 = \kappa_2$ ,  $\mu_1 = \mu_2$  would coincide with those in this paper.

### 6. Experiment verification

The reliability of the new formulae of stress intensity factors has been very well verified by experiments. To show the experimental basis, we examine the differences of the new formulae from the old ones. A simple but representative problem, which is from the Appendix, problem (6), has been taken as an example. The contrast of the new formulae with the old counterpart is shown in Table 1.

Table 1

Crack configuration	SIF at the crack tip a	
	New	$K_I = \frac{P}{\sqrt{\pi a}} \left( \sqrt{\frac{b+a}{b-a}} + \frac{2\sqrt{b^2-a^2}}{a} \right)$
	old	$K_I = \frac{P}{\sqrt{\pi a}} \sqrt{\frac{b+a}{b-a}}$

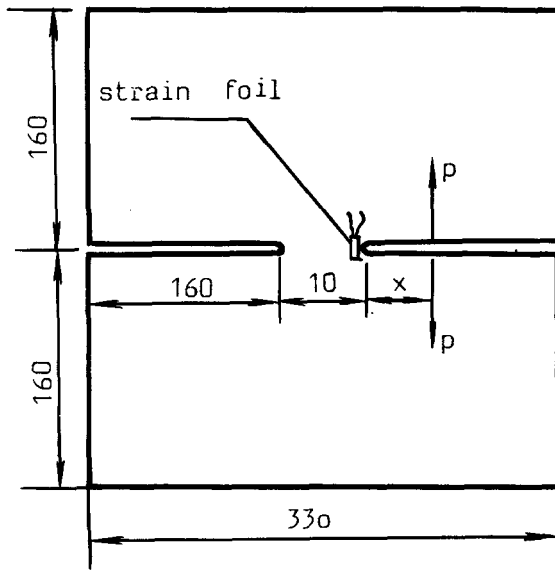

Fig. 5

It can be seen that there is an additional term in the new formula which will become a main term if  $b > 1.5a$ . As the load moves along the surface of the crack away from the tip of it,  $K_{1+a}$  will become smaller and smaller and tend to  $P/\sqrt{\pi a}$  according to the old formula; whereas it will be larger and larger and tend to infinity according to the new formula in this paper ( $b > 1.5a$ ). It is self-evident that the variations of the new and old formula are different completely. According to this, a verification experiment has been made.

A 2 mm thick aluminium plate is taken as a sample, shown in Fig. 5. Two long cuts with sharp tips may be regarded as the model of two collinear semi-infinite cracks. A strain foil is glued closely near to the tip of a cut. The load  $p$  is 1 kg. Let  $x$  denote

the distance between the load point and the cut tip. The values of the strain  $\epsilon$  at the tip are read from a static resistance strain gauge for various values of  $x$ . So the variation of strain  $\epsilon$  may be used to express that of  $K_{1+a}$  approximately.

The experimental results of  $\epsilon$  are shown in Table 2.

The theoretical value of  $K_{1+a}$  in accordance with the new and old formulae are shown in Table 3, where  $a = 5$  mm,  $b = x + a$ .

For further evidence, a comparison of the ratio  $K_{1x}/K_{110}$  with the ratio  $\epsilon_x/\epsilon_{10}$  is listed in Table 4, where the subscript  $x$  denotes the distance between the load point and the cut tip and subscript 10 denotes a relevant value when  $x = 10$ .

The experimental results give a very good verification of the new formulae.

Table 2. Experimental results of  $\epsilon$

$x$ (mm)	10	20	30	40	50	60	70	80	160
$\epsilon$ ( $10^{-6}$ )	76	116	168	208	243	290	335	369	720

Table 3. Theoretical value of  $K_{1+a}$

$x$ (mm)		5	10	20	30	40	50	60
$K_{1+a}$ $\left(\frac{P}{\sqrt{\pi a}}\right)$	New	5.196	7.071	11.022	15.011	19.022	23.014	27.010
	Old	1.732	1.414	1.224	1.154	1.133	1.105	1.087

Table 4. A comparison of  $K_{1x}/K_{110}$  vs.  $\epsilon_x/\epsilon_{10}$

$x$ (mm)		10	20	30	40	50
$\epsilon_x/\epsilon_{10}$		1	1.526	2.210	2.736	3.223
$K_{1x}/K_{110}$	New	1	1.558	2.122	2.690	3.254
	Old	1	0.865	0.816	0.801	0.781

Table 5. A comparison with FEM results for  $K_{I+II}$  ( $P/\sqrt{a}$  or  $M/(a\sqrt{a})$ )

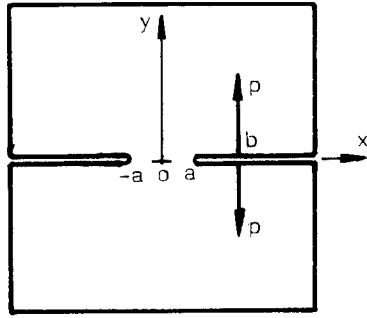
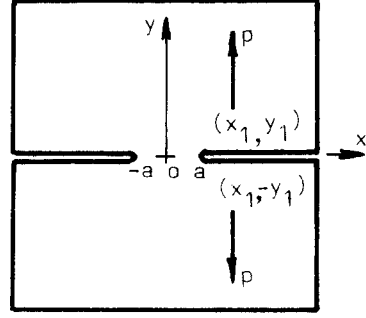
								
$b$	new	old	FEM	$x_1$	$y_1$	new	old	FEM
$1.6a$	2.58	1.17	2.60	$2a$	$a$	2.89	0.88	2.77
$2a$	2.93	0.97	2.89		$2a$	2.82	0.74	2.72
$3a$	3.98	0.79	3.89		$4a$	2.80	0.63	2.72
$4a$	5.09	0.72	4.96	$4a$	$a$	5.09	0.72	4.96
$5a$	6.21	0.69	6.05		$2a$	5.09	0.70	4.95
$10a$	11.85	0.62	11.52		$4a$	5.08	0.66	4.93

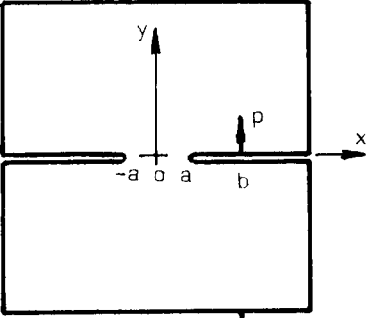
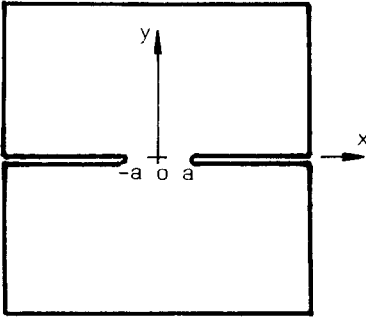
						
$b$	new	old	FEM	new	old	FEM
$2a$	2.87	0.49	2.81	1.12	1.12	1.09
$4a$	5.08	0.36	4.95			

7. A comparison with some FEM results

Some finite element calculations have been made to check the accuracy of the proposed new formulae. A  $20a \times 20a$  plate, where  $a$  is the half length of the bonded segment, is taken to simulate the considered infinite plate. Only a quarter of the plate has been calculated because of the symmetry in geometry. At the vicinity of the crack tip, an elaborate singular element has been used so that the radius of the singular element can be made larger, the extremely

nice mesh at the crack tip avoided and an improved accuracy of the stress intensity factors obtained.

Some FEM (finite element method) results are shown in Table 5, where Poisson's ratio  $\nu$  is 0.3, 19 nodes are placed along the semi-circle of the singular element and another 87 nodes in the remainder of the quarter plate. For comparison the corresponding results of the proposed new formulae and those of the old formulae from the handbooks are also listed. Only mode I stress intensity factors at the crack tip  $+a$  are shown, for mode II stress intensity factors of the new formulae are the same as those of the old.

It is obvious that the FEM results are in excellent agreement with those of the proposed new formulae and the accuracy of the new formulae is further verified.

## References

1. Chinese Aeronautical Research Institute, *Handbook of Stress Intensity Factors*, Publishing House of Sciences (1981) (in Chinese).
2. H. Tada, P.C. Paris and G.R. Irwin, *The Stress Analysis of Cracks Handbook*, Del Research Corp., Hellertown, Pa. (1973).
3. G.C. Sih, *Handbook of Stress Intensity Factors for Researchers and Engineers*. Lehigh University, Bethlehem, Pa. (1973).
4. F. Erdogan, in *Proceedings, Fourth U.S. National Congress of Applied Mechanics* (1962) 547–553.
5. F. Erdogan, *Journal of Applied Mechanics* 30 (1963) 232–236.
6. N.I. Muskhelishvili, *Some Basic Problems of the Mathematical Theory of Elasticity*, P. Noordhoff Limited, Groningen, The Netherlands (1953).
7. D.J. Fan, *The Mathematical Theory of Elasticity*, New Era Publishing House (1983) (in Chinese).

## Notes to Appendices

\*1. There are 3 or 4 numbers for each problem. The first one refers to this paper, the second to [1], the number in parentheses to [2], and the number in the square brackets to [3].

\*2.  $M^*$  represents the resultant moment, which is applied on the upper half-plane by the lower half-plane (refer to Section 4).

\*3. The formulae in this paper are the same as those in [1] only in the case in which the resultant force and moment acting at infinity of each half-plane are equal to zero respectively. Refer to the explanation before (5.4).

\*4. The “+” and “–” in the formulae in [1] and [2] do not coincide with the counterpart of the formulae in this paper. It may be a written error because the problem is the particular case of problem (6).

\*5. There may be a written error of signs in [1] and [3]. Let  $P_1 = Q_1 = 0$  in problem (13) and  $M = 0$  in problem (14), the two problems are the same, but their relevant formulae referred to [1] and [2] are not the same.

Lastly it should be pointed out that for brevity, the loading conditions at infinity have been prescribed in the formulae of the Appendix. For problems (1–12), the traction at infinity is free. For problems (13) and (14), the traction (or restraining force) at infinity must be in equilibrium with the loads close to the crack tips. A half of the traction at infinity is applied in the upper half-plane and the other half in the lower one.

For general cases of loading at infinity, the formulae can be obtained by superposition of them with the formulae of problems (4) and (5).

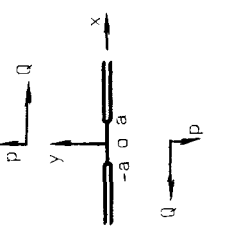
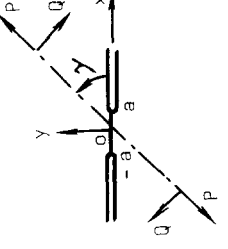
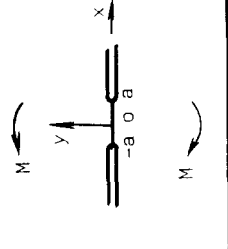
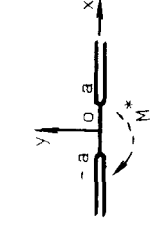
Ref. *1	Crack configuration	SIF in [1]	SIF in this paper
<p>1</p> <p>1.1.10.12 (4.9) [1.2.10.2]</p>		$\begin{Bmatrix} K_I \\ K_{II} \end{Bmatrix} = \frac{1}{\sqrt{\pi a}} \begin{Bmatrix} P \\ Q \end{Bmatrix}$	<p>The statement of the problem is not proper. It should be stated as that in problem 4 and 5.</p>
<p>2</p> <p>1.1.10.9 (4.11)</p>		$\begin{Bmatrix} K_I \\ K_{II} \end{Bmatrix} = \frac{1}{\sqrt{\pi a}} \begin{Bmatrix} P \sin \gamma - Q \cos \gamma \\ P \cos \gamma + Q \sin \gamma \end{Bmatrix}$	
<p>3</p> <p>1.1.10.10 (4.10)</p>		$K_I = \frac{2M}{a \sqrt{\pi a}}$	<p>Noting <math>M^* = M</math>, Problems 3 and 4 are the same.</p>
<p>4*2</p>			$K_{I \pm a} = \pm \frac{2M^*}{a \sqrt{\pi a}}$ $K_{II \pm a} = 0$

Appendix 1. Comparison table of the stress intensity factors (SIF)

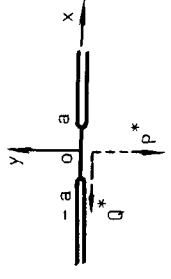
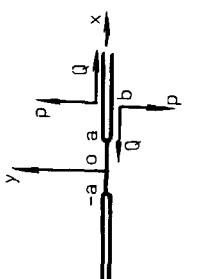
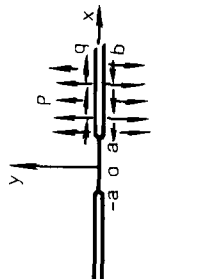
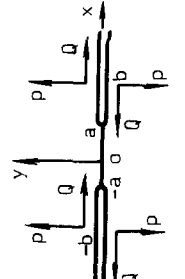
Ref.	Crack configuration	SIF in [1]	SIF in this paper
5			$\left\{ \begin{matrix} K_I \\ K_{II} \end{matrix} \right\}_{\pm a} = \frac{1}{\sqrt{\pi a}} \left\{ \begin{matrix} P^* \\ Q^* \end{matrix} \right\}$
6 1.1.10.3 (4.5)		$\left\{ \begin{matrix} K_I \\ K_{II} \end{matrix} \right\}_{+a} = \frac{1}{\sqrt{\pi a}} \left\{ \begin{matrix} P \\ Q \end{matrix} \right\} \sqrt{\frac{b+a}{b-a}}$ $\left\{ \begin{matrix} K_I \\ K_{II} \end{matrix} \right\}_{-a} = \frac{1}{\sqrt{\pi a}} \left\{ \begin{matrix} P \\ Q \end{matrix} \right\} \sqrt{\frac{b-a}{b+a}}$	$K_{I \pm a} = \frac{P}{\sqrt{\pi a}} \left[ \sqrt{\frac{b \pm a}{b \mp a}} \pm \frac{2\sqrt{b^2 - a^2}}{a} \right]$ $K_{II \pm a} = \frac{Q}{\sqrt{\pi a}} \sqrt{\frac{b \pm a}{b \mp a}}$
7 1.1.10.4 (4.7)		$\left\{ \begin{matrix} K_I \\ K_{II} \end{matrix} \right\}_{\pm a} = \frac{1}{\sqrt{\pi a}} \left\{ \begin{matrix} P \\ q \end{matrix} \right\} \left[ \sqrt{b^2 - a^2} \pm \text{ach}^{-1} \left( \frac{b}{a} \right) \right]$	$K_{I \pm a} = \frac{P}{\sqrt{\pi a}} \left( \sqrt{b^2 - a^2} \pm \frac{b}{a} \sqrt{b^2 - a^2} \right)$ $K_{II \pm a} = \frac{q}{\sqrt{\pi a}} \left[ \sqrt{b^2 - a^2} \pm \text{ach}^{-1} \left( \frac{b}{a} \right) \right]$
8*3 1.1.10.11 (4.6)		$\left\{ \begin{matrix} K_I \\ K_{II} \end{matrix} \right\} = \frac{2}{\sqrt{\pi a}} \left\{ \begin{matrix} P \\ Q \end{matrix} \right\} \frac{b}{\sqrt{b^2 - a^2}}$	<p>The same as those on the left</p>

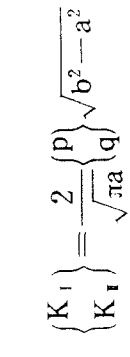
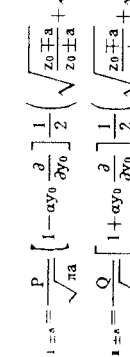
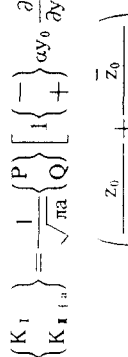
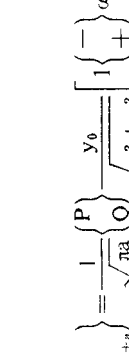
Ref.	Crack configuration	SIF in [1]	SIF in this paper
<p>9</p> <p>1.1.10.5 (4.8)</p>		$\begin{Bmatrix} K_I \\ K_{II} \end{Bmatrix} = \frac{2}{\sqrt{\pi a}} \begin{Bmatrix} P \\ Q \end{Bmatrix} \sqrt{b^2 - a^2}$	<p>The same as those on the left</p>
<p>10*4</p> <p>1.1.10.6 (4.1)</p>	 <p style="text-align: center;"><math>z = x + iy_0 \quad \bar{z} = x - iy_0</math></p>	$K_{I \pm \alpha} = \frac{P}{\sqrt{\pi a}} \left[ 1 - \alpha y_0 \frac{\partial}{\partial y_0} \right] \frac{1}{2} \left( \sqrt{\frac{z_0 \pm a}{z_0 \mp a}} + \sqrt{\frac{\bar{z}_0 \pm a}{\bar{z}_0 \mp a}} \right) \pm \frac{P}{a \sqrt{\pi a}}$ $K_{II \pm \alpha} = \frac{Q}{\sqrt{\pi a}} \left[ 1 + \alpha y_0 \frac{\partial}{\partial y_0} \right] \frac{1}{2} \left( \sqrt{\frac{z_0 \pm a}{z_0 \mp a}} - \sqrt{\frac{\bar{z}_0 \pm a}{\bar{z}_0 \mp a}} \right) \left[ \frac{z_0}{\sqrt{z_0^2 - a^2}} - \frac{\bar{z}_0}{\sqrt{\bar{z}_0^2 - a^2}} \right]$ $\alpha = \begin{cases} \frac{1}{2}(1+\nu) & \text{for plane stress} \\ \frac{1}{2}(1-\nu) & \text{for plane strain} \end{cases}$ <p style="text-align: center;"><math>\nu</math>: Poisson's ratio</p>	$K_{I \pm \alpha} = \frac{P}{\sqrt{\pi a}} \left[ 1 - \alpha y_0 \frac{\partial}{\partial y_0} \right] \frac{1}{2} \left( \sqrt{\frac{z_0 \pm a}{z_0 \mp a}} + \sqrt{\frac{\bar{z}_0 \pm a}{\bar{z}_0 \mp a}} \right) \pm \frac{P}{a \sqrt{\pi a}}$ $K_{II \pm \alpha} = \frac{Q}{\sqrt{\pi a}} \left[ 1 + \alpha y_0 \frac{\partial}{\partial y_0} \right] \frac{1}{2} \left( \sqrt{\frac{z_0 \pm a}{z_0 \mp a}} - \sqrt{\frac{\bar{z}_0 \pm a}{\bar{z}_0 \mp a}} \right) \left[ \frac{z_0}{\sqrt{z_0^2 - a^2}} - \frac{\bar{z}_0}{\sqrt{\bar{z}_0^2 - a^2}} \right]$
<p>11</p> <p>1.1.10.7 (4.2)</p>		$\begin{Bmatrix} K_I \\ K_{II} \end{Bmatrix} = \frac{1}{\sqrt{\pi a}} \begin{Bmatrix} P \\ Q \end{Bmatrix} \begin{Bmatrix} - \\ + \end{Bmatrix} \left[ 1 \pm \alpha y_0 \frac{\partial}{\partial y_0} \right] \left( \frac{z_0}{\sqrt{z_0^2 - a^2}} + \frac{\bar{z}_0}{\sqrt{\bar{z}_0^2 - a^2}} \right)$	<p>The same as those on the left</p>
<p>12</p> <p>1.1.10.8 (4.3)</p>		$\begin{Bmatrix} K_I \\ K_{II} \end{Bmatrix} = \frac{1}{\sqrt{\pi a}} \begin{Bmatrix} P \\ Q \end{Bmatrix} \frac{y_0}{\sqrt{a^2 + y_0^2}} \begin{Bmatrix} - \\ + \end{Bmatrix} \left[ 1 \pm \alpha \frac{a^2}{a^2 + y_0^2} \right]$	<p>The same as those on the left</p>

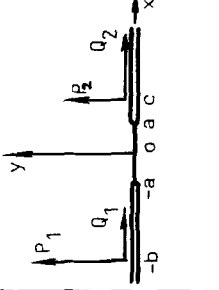
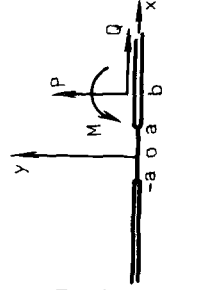

Ref.	Crack configuration	SIF in [1]	SIF in this paper
13*5  1.1.10.1 [1.2.10-1]		$K_{I \pm a} = \frac{1}{2\sqrt{\pi a}} [\pm P_1 \sqrt{\frac{b \mp a}{b \pm a}} \mp P_2 \sqrt{\frac{c \pm a}{c \mp a}}]$ $K_{II \pm a} = \frac{1}{2\sqrt{\pi a}} [\pm Q_1 \sqrt{\frac{b \mp a}{b \pm a}} \mp Q_2 \sqrt{\frac{c \pm a}{c \mp a}}]$	$K_{I \pm a} = \frac{1}{2\sqrt{\pi a}} [P_1 \sqrt{\frac{b \mp a}{b \pm a}} \mp P_2 \sqrt{\frac{c \pm a}{c \mp a}}]$ $\mp \frac{2P_1}{a} \sqrt{b^2 - a^2} \pm \frac{2P_2}{a} \sqrt{c^2 - a^2}$ $K_{II \pm a} = \frac{1}{2\sqrt{\pi a}} [Q_1 \sqrt{\frac{b \mp a}{b \pm a}} \mp Q_2 \sqrt{\frac{c \pm a}{c \mp a}}]$
14  1.1.10.2 (4.4)		$K_{I \pm a} = \frac{P}{2\sqrt{\pi a}} \sqrt{\frac{b \pm a}{b \mp a}} \mp \frac{M}{2\sqrt{\pi a}}$ $\cdot \frac{a}{(b \mp a)\sqrt{b^2 - a^2}}$ $K_{II \pm a} = \frac{Q}{2\sqrt{\pi a}} \sqrt{\frac{b \pm a}{b \mp a}}$	$K_{I \pm a} = \frac{P}{2\sqrt{\pi a}} \sqrt{\frac{b \pm a}{b \mp a}} \mp \frac{M}{2\sqrt{\pi a}} \cdot \frac{a}{(b \mp a)\sqrt{b^2 - a^2}}$ $\pm \frac{1}{a\sqrt{\pi a}} (P\sqrt{b^2 - a^2} + \frac{Mb}{\sqrt{b^2 - a^2}})$ $K_{II \pm a} = \frac{Q}{2\sqrt{\pi a}} \sqrt{\frac{b \pm a}{b \mp a}}$

Appendix 4