

# THE EXPERIMENTAL STUDY ON LOCAL SCOUR AROUND A CIRCULAR PIPE UNDERGOING VORTEX-INDUCED VIBRATION IN STEADY FLOW

Bing Yang<sup>1</sup>, Tao Yang<sup>1</sup>, Jian-Lin Ma<sup>1</sup>, and Jin-Sheng Cui<sup>2</sup>

Key words: local scour, circular pipe, vortex-induced vibration, steady flow, gap-to-diameter ratio.

## ABSTRACT

The local scour around a circular pipe undergoing vortex-induced vibration is investigated experimentally in a water flume. The typical characteristic of local scour is analyzed in detail. The influences of initial gap-to-diameter ratio ( $e_0/D$ ), the mode of pipe vibration and the sand type on the local scour are discussed. Experimental results indicate that there exists strong intensity of scour when the pipe moves close to the surface of the sandy bed. The vibration of the pipe results in the rapid development of sandy bed's scouring. With the increase of gap-to-diameter ratio the distance between the center of the pipe and the position of the maximum scour depth gets larger. The maximum scour depth does not vary monotonically with the gap-to-diameter ratio, but reaches the largest one at certain gap-to-diameter ratio between the values of  $e_0/D = 0$  and 2. There is not much difference of the scour profiles around the vibrating pipe between one degree and two degrees of freedom involved in this study.

## I. INTRODUCTION

The local scour around a circular pipe in steady flow is a complex coupling problem between fluid, structure and soil, and is also a multi-discipline intersecting problem. Studying the problem has an important significance of engineering and a good scientific value, and therefore, many researchers have paid much attention to it. Kjeldsen *et al.* [7] conducted experiments in a flume and presented an empirical expression for predicting maximum depth of scour. The empirical expression

reported by Kjeldsen *et al.* [7] considers the influence of flow velocity, pipe diameter and gravitational acceleration upon the scour. Based on results by Kjeldsen *et al.* [7], Bijker and Leeuwestein [1] carried out a series of supplementary experiments in a flume and discussed the effect of mean diameter of sand grain on the scour. Later Ibrahim *et al.* [5] and Moncada-M *et al.* [11] further discussed the prediction of maximum scour depth. Sumer *et al.* [13] made a dimensional analysis on the influencing factors of equilibrium scour depth and investigated the influence of Reynolds number upon the equilibrium scour depth. From the end of eighties in twenty century, the mechanism of the pipe's suspension attracted the researchers' interests. Mao [10] stated that the pressure difference between two sides of the pipe with a small embedment on the sand bed will induce seepage flow within the sandy bed. Chiew [2] found that the piping is the main cause of the pipe's suspension by qualitative experiments. Sumer *et al.* [17] carried out quantitative experiments about the suspension of the pipe placed on the sandy bed on the basis of the work by Mao [10] and Chiew [2]. They found that the hydraulic gradient ( $i$ ) in the sandy soil is mainly related to the undisturbed flow velocity  $U$  (at the top of the pipe), pipe diameter  $D$ , the initial burial depth  $e_0$  and acceleration of gravity  $g$ . Yang *et al.* [19] investigated the mechanism of pipe's suspension by means of numerical simulation. Moreover, the mechanism of scour are also discussed by some researchers [6, 8, 9, 15, 18].

In fact, the pipe may undergo vortex-induced vibration due to the scour under some circumstances. For example, the vortex-induced vibration of submarine pipeline may occur under the action of ocean currents. About this, Sumer [16], Shen *et al.* [12] and Gao *et al.* [3] made some preliminary studies. In the work by Sumer *et al.* [16], two kinds of experiments were conducted. One was to investigate the influence of transverse vibration of the pipe on the scour, and the other was to investigate the influence of scour on the vibration of the pipe. In the second kind of experiment, the pipe was initially maintained stationary for 30 min at a given flow velocity during which scour reached its equilibrium state, and the pipe was subsequently released and vibrated freely above

Paper submitted 03/06/11; revised 02/24/12; accepted 04/12/12. Author for correspondence: Bing Yang (e-mail: yangb@home.swjtu.edu.cn).

<sup>1</sup> School of Civil Engineering, Southwest Jiaotong University, Chengdu, China.

<sup>2</sup> Institute of Mechanics, Chinese Academy of Sciences, Beijing, China.

the scour hole. Shen *et al.* [12] primarily investigated the vibration of the pipe with two degrees of freedom (Streamwise and transverse) near an erodible sandy bed. Gao *et al.* [3] investigated the coupling effects between pipe vibration and sand scour experimentally. They found that the sand scouring will influence the vibration amplitude and frequency of the pipe, and the vibrating pipe may induce a deeper scour hole than the fixed pipe in their examined range of initial gap-to-diameter ratios ( $-0.25 < e_0/D < 0.75$ ).

Most of the previous studies focus on the local scour around the fixed pipe and only few researchers paid their attention to the local scour around the pipe undergoing vortex-induced vibration. But it has important significance to study this problem, for it can provide the theoretical guideline for the design of submarine pipeline placed on the sandy seabed. Due to its complexity, the underlying mechanism of the coupling interaction between pipe vibration and the scour of sand soil needs to be understood further.

In this paper, the experiments on the local scour around the vibrating pipe are conducted in a flume. The typical characteristic of local scour is described correspondingly. The influences of initial gap-to-diameter ratio, the mode of pipe vibration and the sand type on the scour are discussed.

## II. EXPERIMENTAL SET-UP

A special device is used for the present experiments, which is placed in a water flume, as illustrated in Fig. 1. The flume is 0.5 m wide, 0.6 m high and 19 m long, which can produce steady currents with velocity up to approximate 0.6 m/s. The water depth is kept at 0.35 m in this study. The test pipe was attached to the supporting frame by two connecting shafts, two sliding poles and two sets of springs. The sliding poles can move along the four limit wheels, which are connected to the two supportings by four bearings. The pipe can swing around the gemel installed at the lower ends of the sliding pole. The streamwise (in-line) and transverse vibration of the pipe will be modeled in this study. A laser displacement transducer is employed for the non-contact measurement of the vibrating pipe's displacement. The one with a dynamic resolution of 0.25 mm is used for measurement of vertical displacement and another one with 0.025 mm is for horizontal displacement. The natural frequency of the pipe is obtained by spectrum analysis of free-decay tests in still water.

The time development of scour depth is recorded with a digital camera which is place at one side of the flume to record the scour profile of the sand bed. The fine and transparent scale paper is pasted on the side wall. When the surface of the sand bed deflects, the value of the variation can be obtained by means of the scale paper. When the scour reaches its equilibrium stage, i.e. the surface of sand bed changes little within ten minutes, the longitudinal scour profile is measured with a depth probe, which can slide along the two side-walls of the flume. The test pipes are 0.032 m and 0.050 m in diameter, 0.47 m in length. Only smooth pipes are considered in this

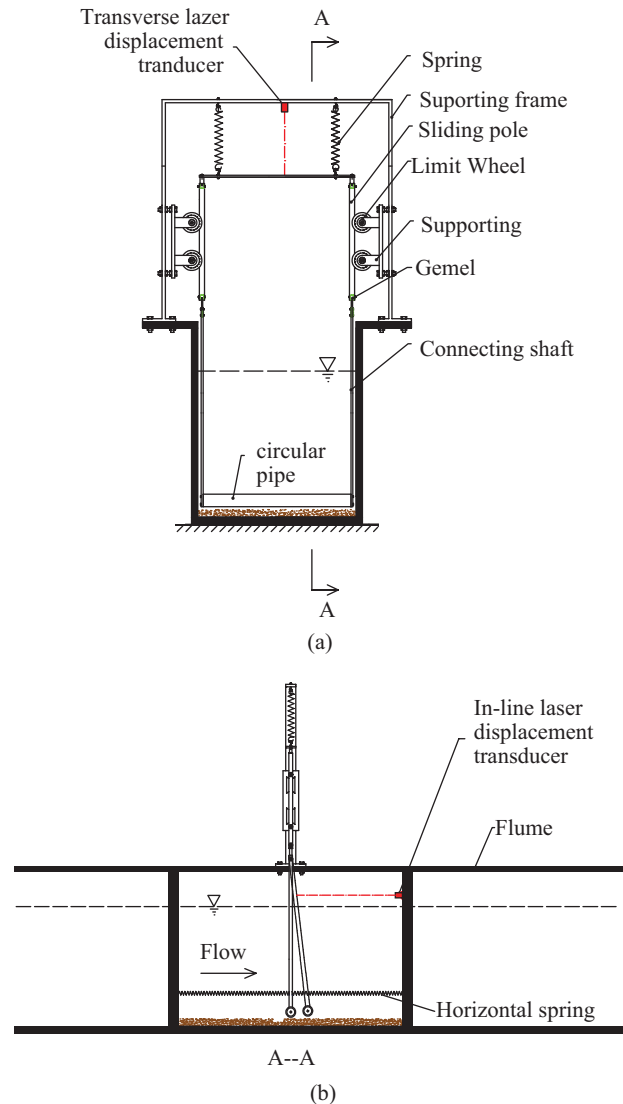

Fig. 1. Schematic diagram of experimental apparatus.

study, i.e.  $k_v/D \approx 0$ . Two kinds of sandy soil are used, whose grain size distribution are shown in Fig. 2. The mean diameter of the sand grain are  $d_{50} = 0.38$  mm with a relative density  $Dr = 0.66$  and  $d_{50} = 0.12$  mm with  $Dr = 0.42$ . The depth of sandy soil is 15 cm. There are about 15 tests carried out in the experiment, as shown in Table 1.

## III. RESULTS AND DISCUSSIONS

### 1. Dimensional Analysis on the Local Scour

The physical quantities which affect the local scour around the circular pipe undergoing vortex-induced vibration are mainly as follows: the flow velocity  $U$ ; the kinetic viscosity of fluid  $\nu$ ; the gravitational acceleration  $g$ ; the mass density of fluid  $\rho$ ; the mean diameter of sand particles  $d_{50}$ ; the mass density of sand grain  $\rho_s$ ; the relative density of sand soil  $Dr$ ; the outer diameter of pipe  $D$ ; the mass of a pipe per meter  $m$ ;

**Table 1. The details of experimental parameters.**

Test No.	$D$ (m)	$U$ (m/s)	$d_{50}$	$Dr$	$e_0/D$	$\theta$	$m^*$	$Vr$	$\xi$	Type of vibration
1	0.050	0.255	0.38	0.66	0	0.039	1.36	6.6	0.0586	transverse
2	0.050	0.255	0.38	0.66	-0.24	0.039	1.36	6.6	0.0586	transverse
3	0.050	0.255	0.38	0.66	0.32	0.039	1.36	6.6	0.0586	transverse
4	0.050	0.255	0.38	0.66	0.44	0.039	1.36	6.6	0.0586	transverse
5	0.050	0.255	0.38	0.66	1.00	0.039	1.36	6.6	0.0586	transverse
6	0.050	0.255	0.38	0.66	2.00	0.039	1.36	6.6	0.0586	transverse
7	0.032	0.255	0.38	0.66	-0.25	0.039	1.97/2.60 ( $m_x^*/m_y^*$ )	7.9	0.0386/0.0565 ( $\xi_x^*/\xi_y^*$ )	Streamwise and transverse
8	0.032	0.255	0.38	0.66	0	0.039	1.97/2.60 ( $m_x^*/m_y^*$ )	7.9	0.0386/0.0565 ( $\xi_x^*/\xi_y^*$ )	Streamwise and transverse
9	0.032	0.255	0.38	0.66	0.34	0.039	1.97/2.60 ( $m_x^*/m_y^*$ )	7.9	0.0386/0.0565 ( $\xi_x^*/\xi_y^*$ )	Streamwise and transverse
10	0.032	0.255	0.38	0.66	0.94	0.039	1.97/2.60 ( $m_x^*/m_y^*$ )	7.9	0.0386/0.0565 ( $\xi_x^*/\xi_y^*$ )	Streamwise and transverse
11	0.032	0.255	0.38	0.66	1.47	0.039	1.97/2.60 ( $m_x^*/m_y^*$ )	7.9	0.0386/0.0565 ( $\xi_x^*/\xi_y^*$ )	Streamwise and transverse
12	0.032	0.255	0.38	0.66	0.32	0.039	2.08	7.1	0.0359	transverse
13	0.032	0.255	0.38	0.66	0.32	0.039	1.76/2.08 ( $m_x^*/m_y^*$ )	7.1	0.0364/0.0521 ( $\xi_x^*/\xi_y^*$ )	Streamwise and transverse
14	0.032	0.255	0.38	0.66	0	0.039	1.97/2.60 ( $m_x^*/m_y^*$ )	7.8	0.0275/0.0543 ( $\xi_x^*/\xi_y^*$ )	Streamwise and transverse
15	0.032	0.255	0.12	0.42	0	0.039	1.97/2.60 ( $m_x^*/m_y^*$ )	7.8	0.0275/0.0543 ( $\xi_x^*/\xi_y^*$ )	Streamwise and transverse

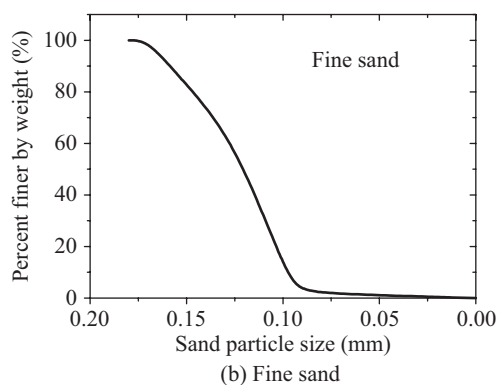
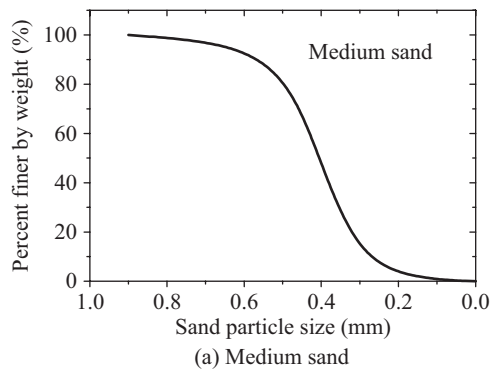
**Fig. 2. Grain size distribution curves of the sand.**

the natural frequency of pipe in still fluid  $f_n$ ; the structural damping factor of the pipe  $\xi$ ; the roughness of pipe surface  $k_s$ ;

the initial gap between pipe and sand bed  $e_0$ . According to the principle of dimensional analysis, the physical quantities above can constitute some dimensionless parameters, i.e.  $Vr$ ,  $m^*$ ,  $K_s$ ,  $k_s/D$ ,  $Re$ ,  $e_0/D$ ,  $\theta$ ,  $Dr$ ,  $s$ ,  $d_{50}/D$ , where  $Vr$  is the reduced velocity and defined as

$$Vr = U / (Df_n) \quad (1)$$

$m^*$  is the mass ratio,  $K_s$  is the stability parameter,  $Re$  is the Reynolds number,  $\theta$  is the Shields number,  $s$  is the relative density, and they are defined as follows:

$$m^* = (4m) / (\pi\rho D^2) \quad (2)$$

$$K_s = (4(m + m_a)\xi) / (\pi\rho D^2) \quad (3)$$

where  $m_a$  is the added mass, and  $m_a = C_A m_d$ .  $C_A$  is the added mass coefficient and  $C_A = 1.0$ .  $m_d$  is the displaced fluid mass by the pipe per meter and  $m_d = (\pi\rho D^2)/4$ .

$$Re = (UD) / \nu \quad (4)$$

$$s = \rho_s / \rho \quad (5)$$

$$\theta = U_f^2 / ((s-1)gd_{50}) \quad (6)$$

in which  $U_f$  is the shear velocity on the surface of sandy bed

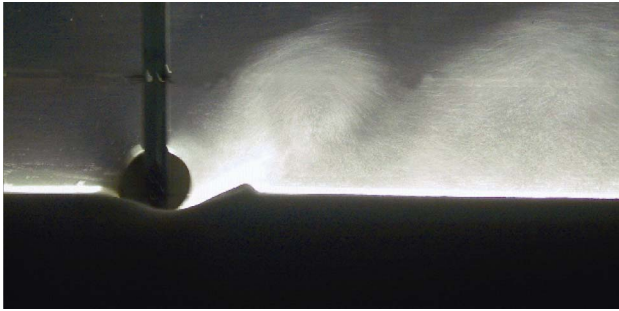

Fig. 3. The typical phenomenon at the initial stage (fine sand).

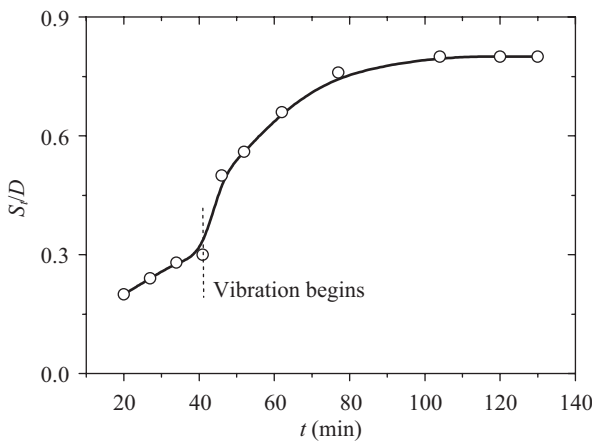

Fig. 4. The development of scour depth with time ( $D = 50$  mm,  $e_0/D = 0$ ,  $\theta = 0.039$ , medium-dense sand:  $d_{50} = 0.38$  mm,  $Dr = 0.66$ , Transverse vibration).

and can be calculated with the Colebrook-White formula, i.e.  $U/U_f = 8.6 + 2.5\ln(D/2k_b)$ , here  $k_b$  is the roughness of sandy bed's surface and usually taken as  $2.5 d_{50}$  [14]. Therefore, the equilibrium scour depth ( $S$ ) can be expressed as

$$S/D = f(Vr, m^*, K_s, k_s/D, Re, e_0/D, \theta, Dr, s, d_{50}/D) \quad (7)$$

## 2. The Typical Characteristic of Local Scour

Fig. 3 shows the typical phenomenon on the dynamic response between the vibrating pipe and the sandy bed. It can be seen from the figure that when the pipe moves close to the surface of the sandy bed, a lot of sand grain is lifted from the surface by the fluid at the wake region. It indicates that there exists strong intensity of scour at the surface of the sandy bed when the pipe contacts to the surface of the sandy bed. The development of scour depth with time for the case of  $e_0/D = 0$  and  $\theta = 0.039$  is illustrated in Fig. 4. It is indicated from the figure that an inflection point appears at the curve of scour development. The scour develops slowly before the inflection point appears, and after the inflection point the scour beneath the pipe develops quickly. According to the observation of experiments, the time at which the inflection point appears corresponds to the occurrence of the pipe's vibration.

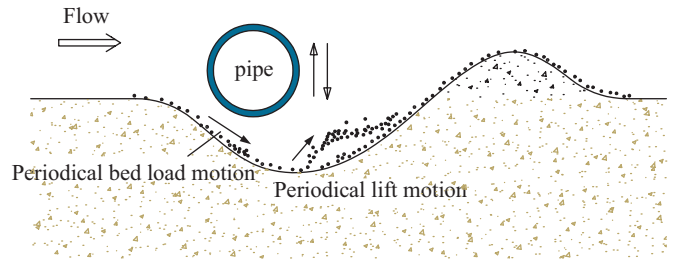
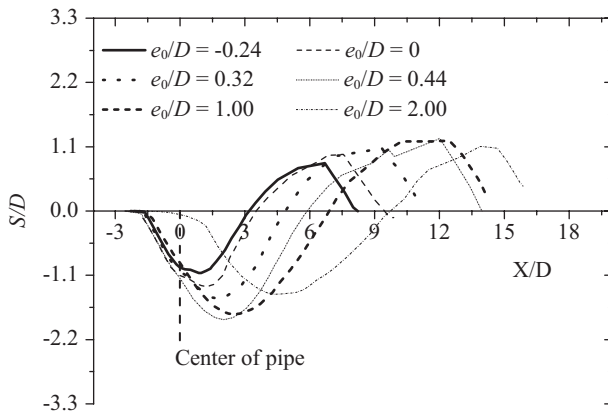

Fig. 5. The forms of motion for the sand grain beneath the pipe undergoing vibration (transverse vibration).

It indicates that the vibration of the pipe results in the rapid development of sandy bed's scour. It is seen from Fig. 4 that the scour depth has increased to the value of  $0.3D$  when the pipe begins to vibrate. According to the observation, there exist mainly two forms of motion for the sand grain on the surface of sandy bed beneath the pipe during the course of vibrating, as depicted in Fig. 5. The first form is periodical bed load motion of the sand grain at the upstream side of scour hole. When the pipe moves down, the first form of motion appears. When the pipe moves up from the lowest position, the second form of motion (i.e. periodical lift motion of the sand grain at the downstream side of the scour hole) occurs.

## 3. The Influences of Initial Gap-to-Diameter Ratio ( $e_0/D$ ) on the Local Scour

Fig. 6(a) illustrates the equilibrium scour profile around a transverse vibrating pipe for the case of various gap-to-diameter ratios. The Shields number ( $\theta$ ) is 0.039 in this experiments, which is calculated according to the undisturbed incoming flow. Therefore, the scour far away from the center of the pipe is clear-water scour. The pipe with  $m^* = 1.36$  vibrates only in transverse direction. The structural damping factor of the pipe ( $\xi$ ) is 0.0586 and the reduced velocity ( $Vr$ ) is 6.6. It can be seen from the figure that the position of maximum scour depth locates at the downstream side of the pipe's center for all the gap-to-diameter ratios in this study. With the increase of gap-to-diameter ratio the distance between the center of the pipe and the position of the maximum scour depth gets larger. It is also indicated from the figure that the maximum scour depth does not vary monotonically with the increase of gap-to-diameter ratio, but reaches the largest one at certain gap-to-diameter ratio between the values of  $e_0/D = 0$  and  $e_0/D = 2$ . The vibrating amplitudes corresponding to the equilibrium scour profiles in Fig. 6(a) are plotted in Fig. 6(b). It is observed from the figure that the vibrating amplitude does also not vary monotonically with the gap-to-diameter ratio. According to the results by Yang *et al.* [20], with the decrease of the gap between the pipe and the sandy bed, the maximum scour depth tends to increase for the case of the local scour around the fixed pipe. Due to the influence of vibration, the variation of maximum scour depth with the gap-to-diameter ratio presents a different law, compared with those for the fixed pipe case. Therefore, the characteristic of local scour is



(a)

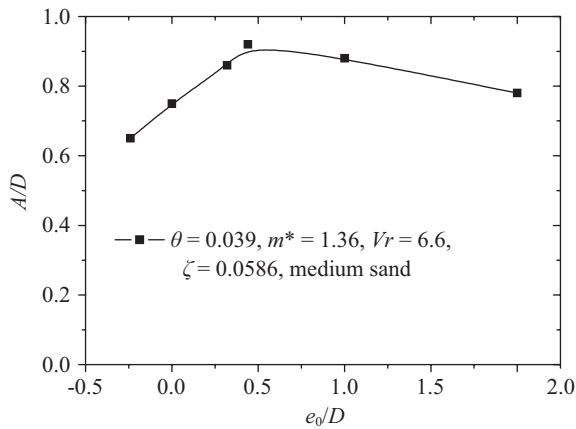

(b)

**Fig. 6.** The characteristic of scour around a vibrating pipe with one degree of freedom. (a) Equilibrium scour profiles around a transverse vibrating pipe with various gap-to-diameter ratios ( $D = 0.05$  m,  $\theta = 0.039$ ,  $m^* = 1.36$ ,  $Vr = 6.6$ ,  $\zeta = 0.0586$ , medium-dense sand), and (b) Vibrating amplitude corresponding to the equilibrium scour profiles in the Fig. 6(a).

affected by the combination of gap-to-diameter ratio and the pipe's vibrating for the case of vibrating pipe. For instance, the maximum scour depth corresponding to  $e_0/D = 0$  is smaller than that corresponding to  $e_0/D = 0.32$  due to the larger vibrating amplitude of the pipe for the  $e_0/D = 0.32$  case. The maximum scour depth corresponding to  $e_0/D = 1.00$  is larger than that corresponding to  $e_0/D = 2.00$  due to the larger gap-to-diameter ratio for the  $e_0/D = 2.00$  case.

Fig. 7(a) gives the equilibrium scour profiles around the vibrating pipe with two degrees of freedom for various gap-to-diameter ratios. The corresponding vibration amplitudes of the pipe for equilibrium scour profiles of various gap-to-diameter ratios are plotted in Fig. 7(b). It is indicated from the figure that the variation of scour depth with gap-to-diameter ratio for two degrees of freedom case presents a similar law with that for one degree of freedom case.

**4. The Influences of Vibration Mode of the Pipe and the Soil Type on the Local Scour**

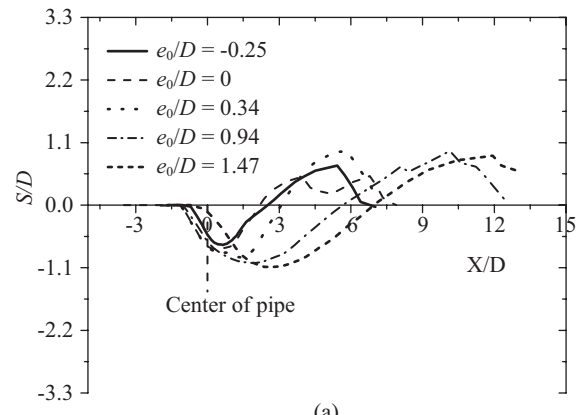

(a)

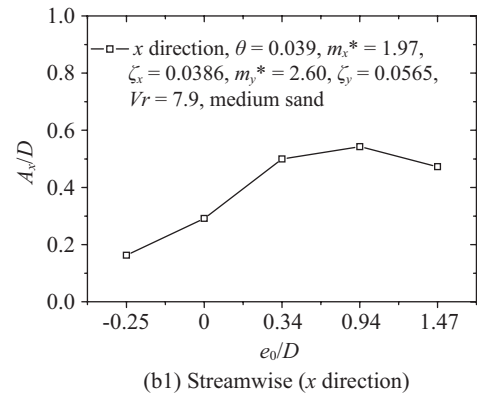

(b1) Streamwise (x direction)

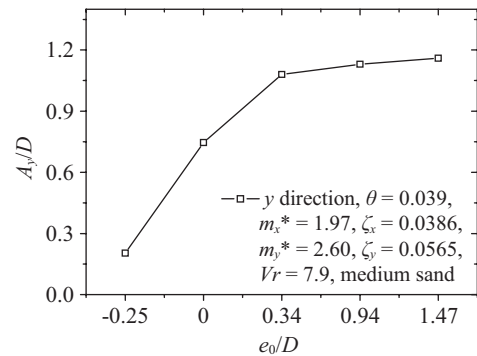

(b2) Transverse (y direction)

**Fig. 7.** The characteristic of scour around a vibrating pipe with two degrees of freedom. (a) Equilibrium scour profiles around a vibrating pipe with two degrees of freedom (transverse and streamwise) for various gap-to-diameter ratios ( $D = 0.032$  m,  $\theta = 0.039$ ,  $m_x^* = 1.97$ ,  $\zeta_x = 0.0386$ ,  $m_y^* = 2.60$ ,  $\zeta_y = 0.0565$ ,  $Vr = 7.9$ , medium-dense sand), and (b) Vibrating amplitude corresponding to the equilibrium scour profiles in the Fig. 7(a) above.

The scour profiles around the vibrating pipe with one and two degrees of freedom are plotted in Fig. 8. The gap-to-diameter ratio in the figure is 0.32. The transverse vibrating amplitude of the pipe with  $m^* = 2.08$  and  $\xi = 0.0359$  is  $0.84D$ . The experimental parameters for the pipe with two degrees of freedom are as follows:  $m_x^* = 1.76$ ,  $\xi_x = 0.0364$ ,  $m_y^* = 2.08$ ,  $\xi_y = 0.0521$ ,  $A_x/D = 0.63$ ,  $A_y/D = 0.99$ . The reduced velocity ( $Vr$ ) is 7.1 and Shields number ( $\theta$ ) which corresponds to the

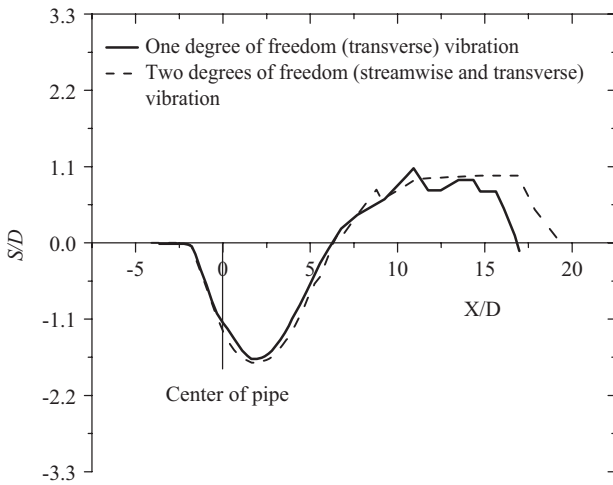

Fig. 8. The comparison of scour profiles around the vibrating pipe between one degree (transverse) and two degrees of freedom (Streamwise and transverse);  $e_0/D = 0.32$ ; Transverse vibration:  $m_x^* = 2.08$ ,  $\zeta = 0.0359$ ,  $A/D = 0.84$ ; Two degrees of freedom vibration:  $m_x^* = 1.76$ ,  $\zeta_x = 0.0364$ ,  $m_y^* = 2.08$ ,  $\zeta_y = 0.0521$ ;  $A_x/D = 0.63$ ,  $A_y/D = 0.99$ ;  $Vr = 7.1$ ,  $\theta = 0.039$ , medium-dense sand.

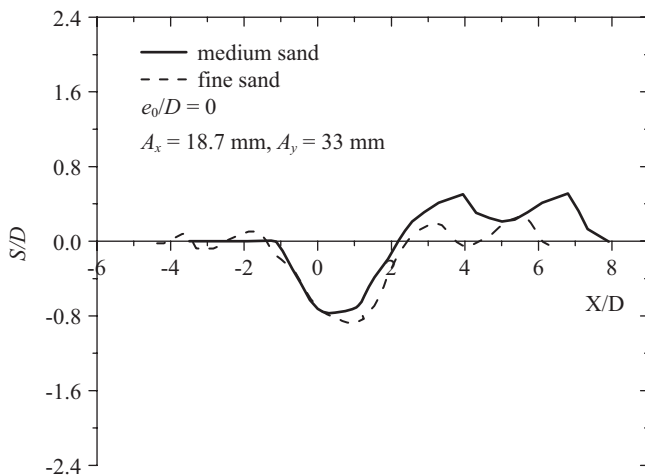

Fig. 9. Comparison of scour profiles around the vibrating pipe under the condition of different types of sand ( $e_0/D = 0$ ,  $m_x^* = 1.97$ ,  $\zeta_x = 0.0275$ ;  $m_y^* = 2.60$ ,  $\zeta_y = 0.0543$ ;  $Vr = 7.8$ ,  $U = 0.255$  m/s).

undisturbed incoming flow is 0.039 for the two cases. It can be seen from the figure that there is not much difference of the scour profiles around the vibrating pipe between one degree and two degrees of freedom in this study. The maximum scour depths for two cases are almost consistent.

Fig. 9 presents the scour profiles of medium and fine sand around the vibrating pipe with two degrees of freedom. The gap-to-diameter ratio in the figure is  $e_0/D = 0$ . The streamwise vibrating amplitude ( $A_x$ ) is 18.7mm (about  $0.37D$ ) and the transverse vibrating amplitude ( $A_y$ ) is 33 mm (about  $0.66D$ ). The mass ratio are  $m_x^* = 1.97$  and  $m_y^* = 2.60$ . The reduced velocity ( $Vr$ ) is 7.8 and the undisturbed incoming flow is  $U = 0.255$  m/s. It is observed from the figure that the scour profiles

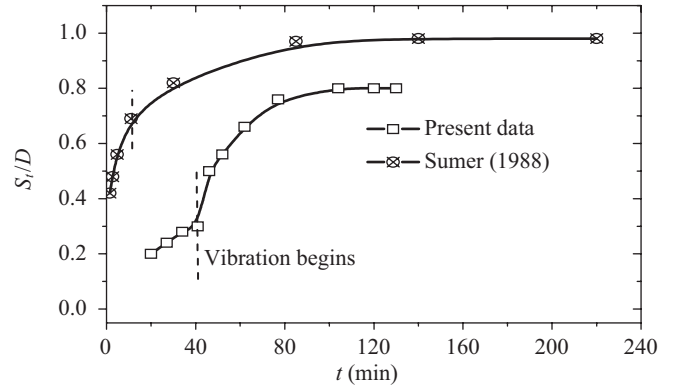

Fig. 10. the development of scour with time (Present data:  $D = 50$  mm,  $e_0/D = 0$ ,  $\theta = 0.039$ ,  $d_{50} = 0.38$  mm, Transverse vibration; Sumer, 1988:  $D = 101$  mm,  $e_0/D = 0$ ,  $\theta = 0.1$ ,  $d_{50} = 0.36$  mm, Transverse vibration).

for the two cases are similar. The maximum scour depth for the case of fine sand is a little larger than that for the case of medium sand. In a whole, the local scour of sandy bed beneath the pipe is influenced weakly due to the difference of sand soil in this study.

### 5. Comparison with Previous Results

Fig. 10 presents the comparison of development of scour with time between the results by Sumer *et al.* [16] and those by present study. The Shields number ( $\theta$ ) is 0.039 and the mean diameter of sand grain ( $d_{50}$ ) is 0.38 mm in present study, which means the scour is in the range of clear-water scour. The experimental parameters are  $d_{50} = 0.36$  mm and  $\theta = 0.1$  in the study by Sumer *et al.* [16], which means the scour is mobile-bed scour. The initial gap-to-diameter ratio ( $e_0/D$ ) is 0 for both cases. It is observed from the figure that there is a clear inflection point at which the vibration of the pipe begins to occur on the curve of scour development with time in present study, but the inflection point is not clear in the results by Sumer *et al.* [16]. The possible reason may be that the scour in the study by Sumer *et al.* [16] is mobile-bed scour which blankets the added scour due to the vibration of pipe.

A comparison of present results with previous results by Gao *et al.* [3], Sumer *et al.* [16], Hansen *et al.* [4] and Yang *et al.* [20] is made in Fig. 11. It is noted that the results by present study, Gao *et al.* [3] and Sumer *et al.* [16] correspond to the vibrating pipe case, and those by Hansen *et al.* [4] and Yang *et al.* [20] correspond to the fixed pipe case. It can be seen from the figure that the scour depth for the case of vibrating pipe is larger than that for the fixed pipe case. There are some differences between present results and those by Gao *et al.* [3] and Sumer *et al.* [16] for the vibrating pipe case. In present study the normalized scour depth ( $S/D$ ) increases with the increasing gap-to-diameter ratio when  $e_0/D < 0.44$  and decreases with it when  $e_0/D > 0.44$ . In the results by Gao *et al.* [3] and Sumer *et al.* [16], the dimensionless scour depth

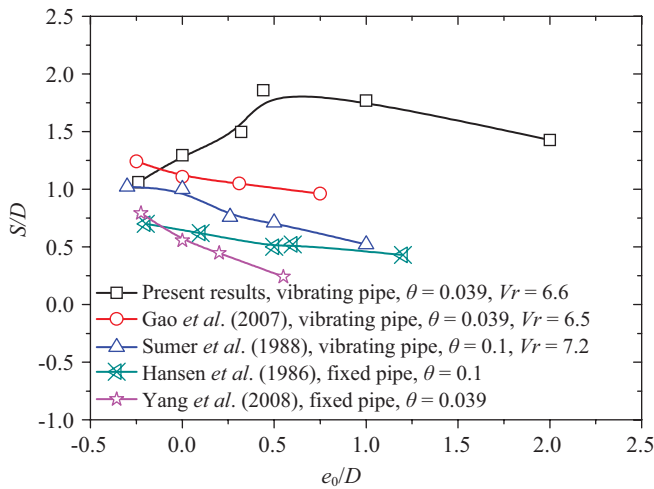

Fig. 11. Comparison with previous results.

( $S/D$ ) varies monotonically with  $e_0/D$  and decreases with the increase of gap-to-diameter ratio. The reason of the difference possibly is that the variation of vibrating amplitude of the pipe with  $e_0/D$  is different.

#### IV. CONCLUSION

Most of the previous studies focus on the local scour around the fixed pipe and only few researchers paid their attention to the local scour around the pipe undergoing vortex-induced vibration. The experiments upon the local scour around the vibrating pipe are conducted in a flume in this paper. The mainly conclusions can be concluded as follows:

- 1) There exists strong intensity of scour when the pipe moves to the surface of the sandy bed. The vibration of the pipe results in the rapid development of sandy bed's scour. There exist mainly two forms of motion for the sand grain on the surface of sandy bed beneath the pipe during the course of vibrating, i.e. the periodical bed load motion of the sand grain at the upstream side of scour hole and the periodical lift motion of the sand grain at the downstream side of the scour hole.
- 2) With the increase of gap-to-diameter ratio the distance between the center of the pipe and the position of the maximum scour depth gets larger. The maximum scour depth does not vary monotonically with the gap-to-diameter ratio, but becomes the largest one at certain value of gap-to-diameter ratio between the values of  $e_0/D = 0$  and  $e_0/D = 2$ . The variation of scour depth with gap-to-diameter ratio for two degrees of freedom case presents a similar law with that for one degree of freedom case.

There is not much difference of the scour profiles around the vibrating pipe between one degree and two degrees of freedom involved in this study.

#### ACKNOWLEDGMENTS

This work is financially supported by National Natural Science Foundation of China (Grant No. 10902112).

#### REFERENCES

1. Bijker, E. W. and Leeuwestein, W., "Interaction between pipelines and the seabed under the influence of waves and currents," *Seabed Mechanics, Proceedings of Symposium of IUTAM/IUGG*, International Union of Theoretical and Applied Mechanics/International Union of Geology and Geophysics, pp. 235-242 (1984).
2. Chiew, Y. M., "Mechanics of local scour around submarine pipelines," *Journal of Hydraulic Engineering*, ASCE, Vol. 116, No. 4, pp. 515-529 (1990).
3. Gao, F. P., Yang, B., Wu, Y. X., and Yan, S. M., "Steady current induced seabed scour around a vibrating pipeline," *Applied Ocean Research*, Vol. 28, pp. 291-298 (2007).
4. Hansen, E. A., Fredsoe, J., and Mao, Y., "Two dimensional scour below pipelines," *Proceedings of 5th International Symposium on Offshore Mechanics and Arctic Engineering*, ASME, Tokyo, Japan, Vol. 3, pp. 670-678 (1986).
5. Ibrahim, A. and Nalluri, C., "Scour prediction around marine pipelines," *Proceedings of 5th International Symposium on Offshore Mechanics and Arctic Engineering*, Tokyo, Japan, pp. 679-684 (1986).
6. Jensen, B. L., Sumer, B. M., Jensen, H. R., and Fredsoe, J., "Flow around and forces on a pipeline near a scoured bed in steady current," *Journal of Offshore Mechanics and Arctic Engineering*, Vol. 112, pp. 206-213 (1990).
7. Kjeldsen, S. P., Gjorsvik, O., Bringaker, K. G., and Jacobsen, J., "Local scour near offshore pipelines," *Proceedings of 2nd International Conference On Port and Ocean Engineering under Arctic Conditions*, University of Iceland, Iceland, pp. 308-331 (1973).
8. Li, Y. C. and Lu, L., "Numerical simulation of moving scour boundary around submarine pipelines based on turbulence model," *Shipbuilding of China*, Vol. 45 (plus), pp. 209-216 (2004). (in Chinese)
9. Li, Z. L., Dong, C. L., Yuan, Y. L., and Dong, S. P., "Study of scouring of submarine pipelines in the Shengli oil field by flow visualizing," *Journal of Experiments in Fluid Mechanics*, Vol. 17, No. 3, pp. 49-52 (2003). (in Chinese)
10. Mao, Y., "Seabed scour under pipelines," *Proceedings of 7th International Symposium on Offshore Mechanics and Arctic Engineering*, Houston, Texas, pp. 33-38 (1988).
11. Moncada-M, A. T. and Aguirre-Pe, J., "Scour below pipeline in river crossings," *Journal of Hydraulic Engineering*, Vol. 125, No. 9, pp. 953-958 (1999).
12. Shen, Z. H., Liu, Y. B., Li, Q. P., Huang, Q. H., and Zhu, F. R., "Experiments on interaction between current-induced vibration and scour of submarine pipelines on sandy bottom," *China Ocean Engineering*, Vol. 14, No. 4, pp. 423-434 (2000).
13. Sumer, B. M. and Fredsoe, J., "Scour below pipelines in wave," *Journal of Waterway, Port, Coastal and Ocean Engineering*, ASCE, Vol. 116, No. 3, pp. 307-323 (1990).
14. Sumer, B. M. and Fredsoe, J., *The Mechanics of Scour in the Marine Environment*, World Scientific Publishing Company, New Jersey (2002).
15. Sumer, B. M., Jensen, H. R., Mao, Y., and Fredsoe, J., "Effect of lee-wake on scour below pipelines in current," *Journal of Waterway, Port, Coastal and Ocean Engineering*, Vol. 114, No. 5, pp. 599-614 (1988).
16. Sumer, B. M., Mao, Y., and Fredsoe, J., "Interaction between vibrating pipe and erodible bed," *Journal of Water, Port, Coastal, and Ocean Engineering*, Vol. 114, No. 1, pp. 81-92 (1988).
17. Sumer, B. M., Truelsen, C., Sichmann, T., and Fredsoe, T., "Onset of scour below pipelines and self-burial," *Coastal Engineering*, Vol. 42, pp. 313-335 (2000).
18. Yang, B., Gao, F. P., and Wu, Y. X., "Local scour of sandy seabed around

- pipeline under the influence of unidirectional currents,” *Shipbuilding of China*, Vol. 45 (plus), pp. 281-288 (2004). (in Chinese)
19. Yang, B., Gao, F. P., and Wu, Y. X., “Numerical study of the occurrence of pipeline spanning under the influence of steady current,” *Ship Building of China*, Vol. 46 (supp.), pp. 221-226 (2005). (in Chinese)
20. Yang, B., Gao, F. P., and Wu, Y. X., “Experimental study on local scour of sandy seabed under submarine pipeline in unidirectional currents,” *Engineering Mechanics*, Vol. 25, No. 3, pp. 206-210 (2008). (in Chinese)